

Quick Processing Tutorial

This tutorial will guide you through the steps to draw the following map using the Quick Processing stencil.

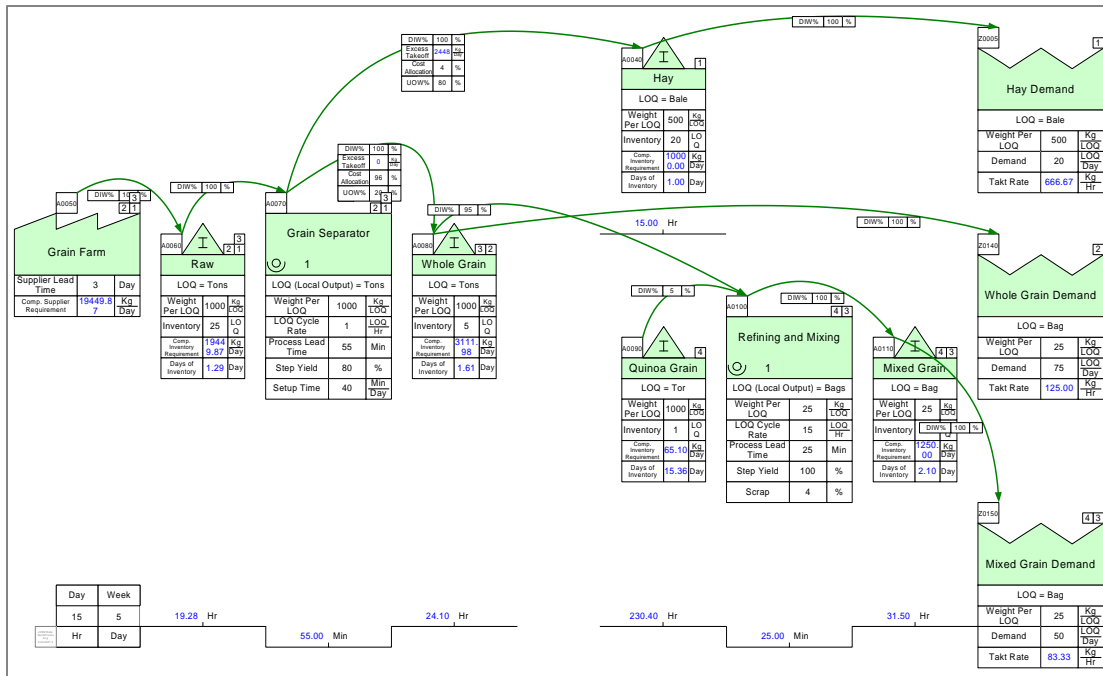

Step 1: Start eVSM

1 On your Desktop, click the "Start eVSM" icon.

2 If you see a message like this, you must "Enable" macros.

3 Click to enable macros.

4 Click "Trust all from publisher" to avoid the security notice in future.

Recycle Bin

Start eVSM

Microsoft Visio Security Notice

Microsoft Office has identified a potential security concern.

Note: The digital signature is valid, but the signature is from a publisher whom you have not yet chosen to trust.

File Path: C:\Program Files\evsm\Setup\Solutions\evsmIcons.vss

Macros have been disabled. Macros might contain viruses or other security hazards. Do not enable this content unless you trust the source of this file.

[More information](#)

[Show Signature Details](#)

Trust all from publisher Enable Macros Disable Macros

Step 2: Learn eVSM Basics

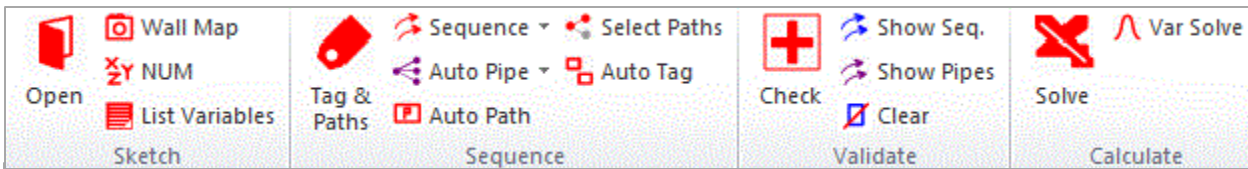

Quick Processing

Sketch Processing

2 Avoid re-sizing eVSM shapes. Instead grow the drawing page when needed. To resize the page, hold down the “Ctrl” key, and then drag any page edge to the required size. This method works on all four edges of the page.



5 Save your Visio file and then insert a new page via the right-mouse menus on the page-tabs.

VSM

Quick_eVSM

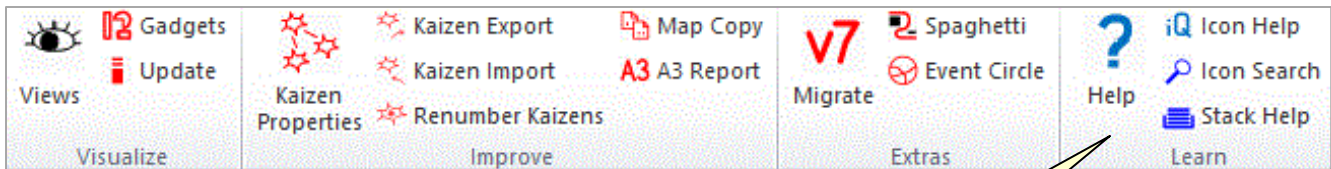

1 eVSM Help resources are available here. Try clicking each help button and learn what it does.

3 Blue icons in the main stencil represent families of shapes. Drag out the Transport icon.

4 Use the shape's right-mouse menus to turn it into a car

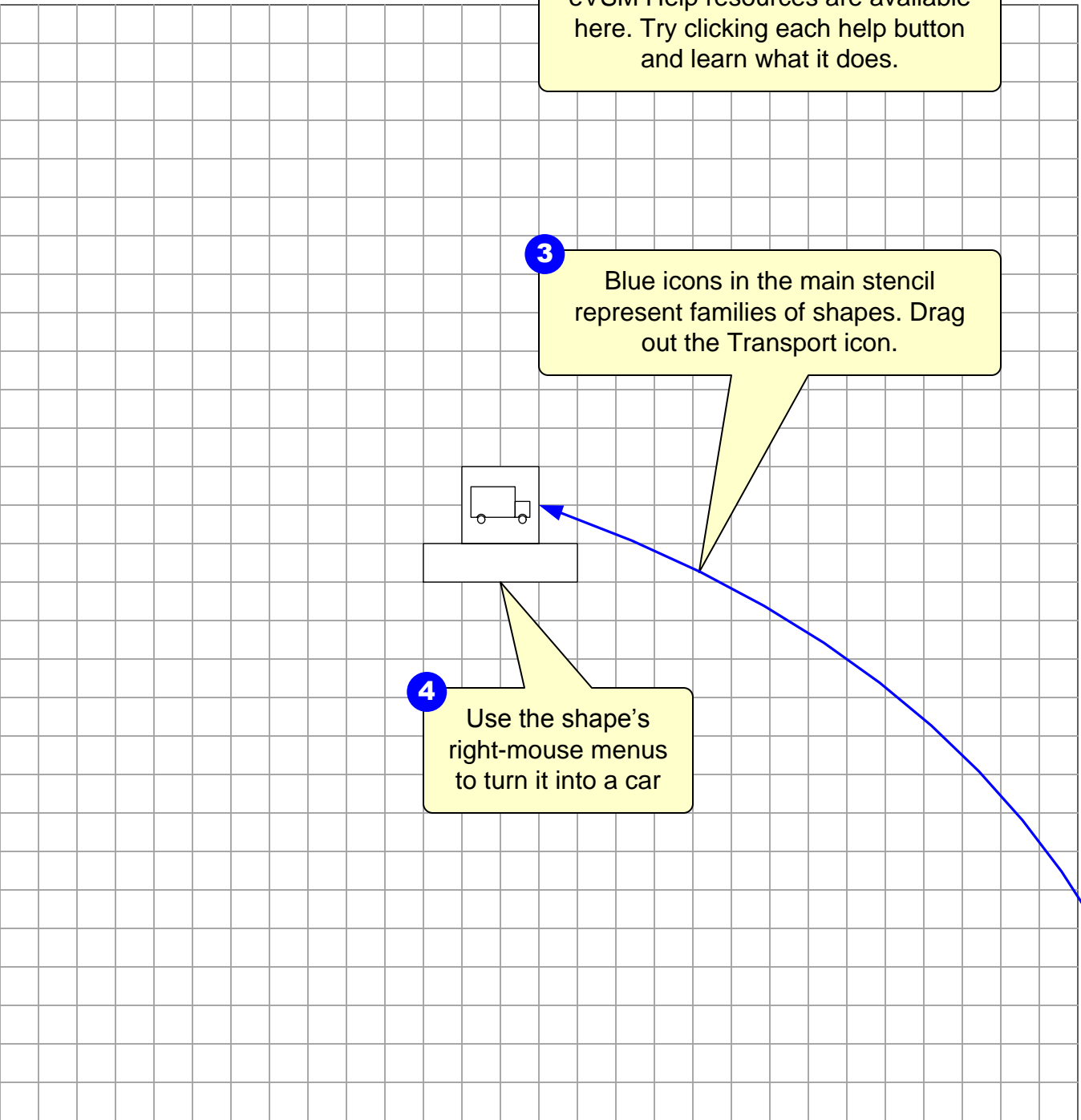
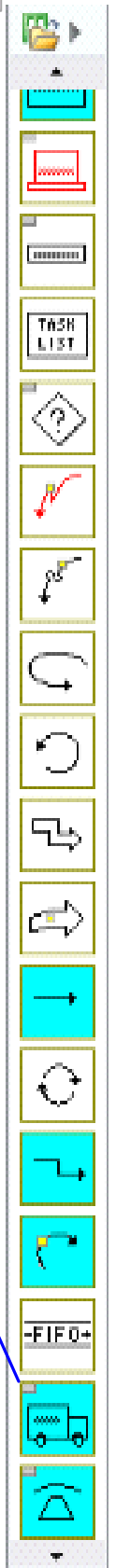

Step 3: Initiate the map for Quick Processing

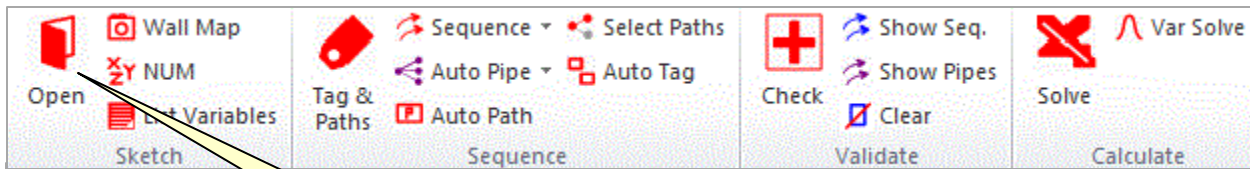



1 Click the Open button and select the Quick Processing Stencil and click OK.

2 Drag out the red icons from the Quick Processing Stencil first. This is very important!

Quick Processing















Sketch Processing

 Time and Unit Center

 Customer Center

5 Enter the available hours per day and days per week.

Day	Week
15	5
Hr	Day

Views 	 Gadgets	 Kaizen Properties	 Kaizen Export	 Kaizen Import	 Renumber Kaizens	 Map Copy	 A3 Report	v7 Migrate	 Spaghetti	 Event Circle	Help 	 Icon Help	 Icon Search	 Stack Help
	Update 	Visualize	Improve	Extras	Learn									

3
Align all shapes to the grid as you drop them.

Z0005			1
Grain Customer			
Demand Weight	1875	Lb	Day
Takt Rate	Auto	Lb	Hr

4
Enter the demand weight.

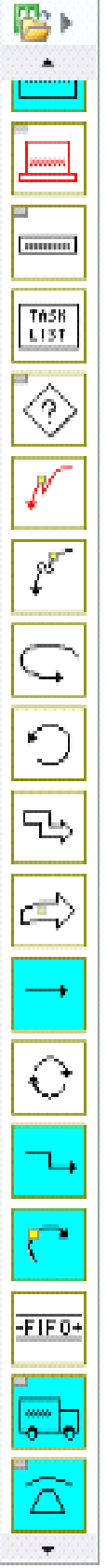

-
-
-
-
-
-
-
-
-
-
-
-
-
-
-
-
-
-

Step 4: Draw the Flow for Raw Grains

Wall Map NUM List Variables Sketch	Tag & Paths Auto Pipe Auto Path Sequence	Select Paths Auto Tag Validate	Check Show Seq. Show Pipes Clear Validate	Var Solve Calculate
---	---	--------------------------------------	---	------------------------

Quick Processing

Sketch Processing

Supplier Center

Inventory Center

Activity Center

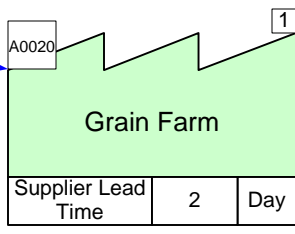

2 Fill in the data as shown for all shapes. Double-click the unit to change from Week to Day.

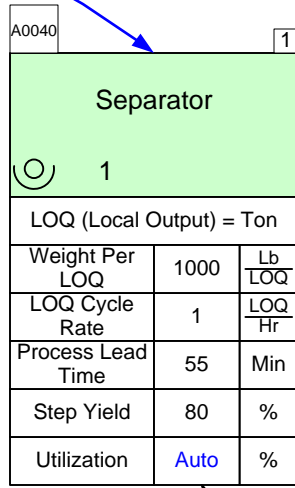
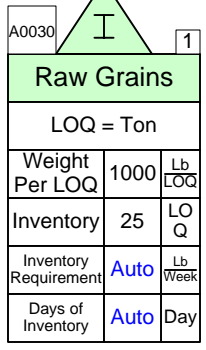

1 Green icons in the Quick eVSM stencils are called "Centers." Use these to create the flow.

3 Do not change any blue "Auto" values. These will get calculated automatically later.

Day	Week
15	5
Hr	Day

Views	Gadgets Update	Kaizen Properties Kaizen Export Kaizen Import Renumber Kaizens	Map Copy A3 Report	v7 Migrate Spaghetti Event Circle	Help Icon Help Icon Search Stack Help
Visualize		Improve		Extras	Learn

A0050		1
Grains		
LOQ = Ton		
Weight Per LOQ	1000	$\frac{\text{Lb}}{\text{LOQ}}$
Inventory	5	$\frac{\text{LOQ}}{\text{Q}}$
Inventory Requirement	Auto	$\frac{\text{Lb}}{\text{Week}}$
Days of Inventory	Auto	Day

Z0005		1
Grain Customer		
Demand Weight	1875	$\frac{\text{Lb}}{\text{Day}}$
Takt Rate	Auto	$\frac{\text{Lb}}{\text{Hr}}$

-
-
-
-
-
-
-
-
-
-
-
-
-
-
-

Step 5: Draw the Flow for Hay

Wall Map	Sequence ▾	Select Paths	Check	Show Seq.	Var Solve
Open	Auto Pipe ▾	Auto Tag	Clear	Show Pipes	Solve
List Variables	Auto Path			Validate	Calculate
Sketch		Sequence		Calculate	

Quick Processing
 Sketch Processing



Customer Center



Inventory Center

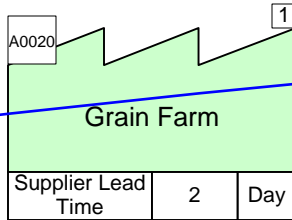

1

Drag out a Customer Center and Inventory Center for the Hay flow.

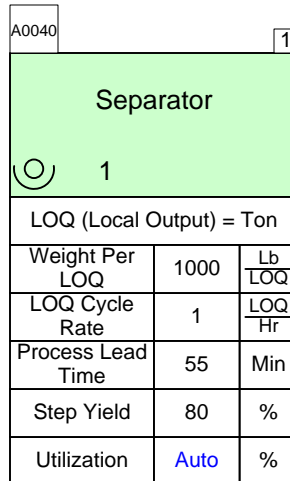
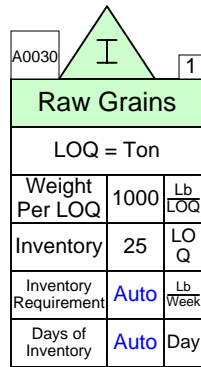

Day	Week
15	5
Hr	Day

Views	Gadgets	Kaizen Export	Map Copy	v7 Migrate	Spaghetti	Icon Help
	Update	Kaizen Import	A3 A3 Report	Event Circle	Icon Search	Stack Help
Visualize	Kaizen Properties	Improve		Extras	Learn	

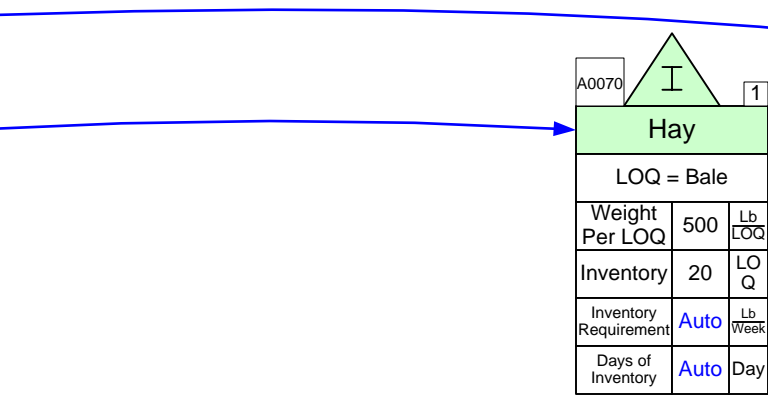

A0050	I	1
Grains		
LOQ = Ton		
Weight Per LOQ	1000	Lb LOQ
Inventory	5	LO Q
Inventory Requirement	Auto	Lb Week
Days of Inventory	Auto	Day

2 Fill in the data as shown for all shapes.

Z0005		1
Grain Customer		
Demand Weight	1875	Lb Day
Takt Rate	Auto	Lb Hr

Step 6: Draw the Flow for Mixed Grain

Wall Map	Sequence ▾	Select Paths	Show Seq.	Var Solve
Open	Auto Pipe ▾	Auto Tag	Show Pipes	Solve
List Variables	Tag & Paths	Auto Path	Clear	
Sketch	Sequence	Validate	Calculate	

Quick Processing

Sketch Processing

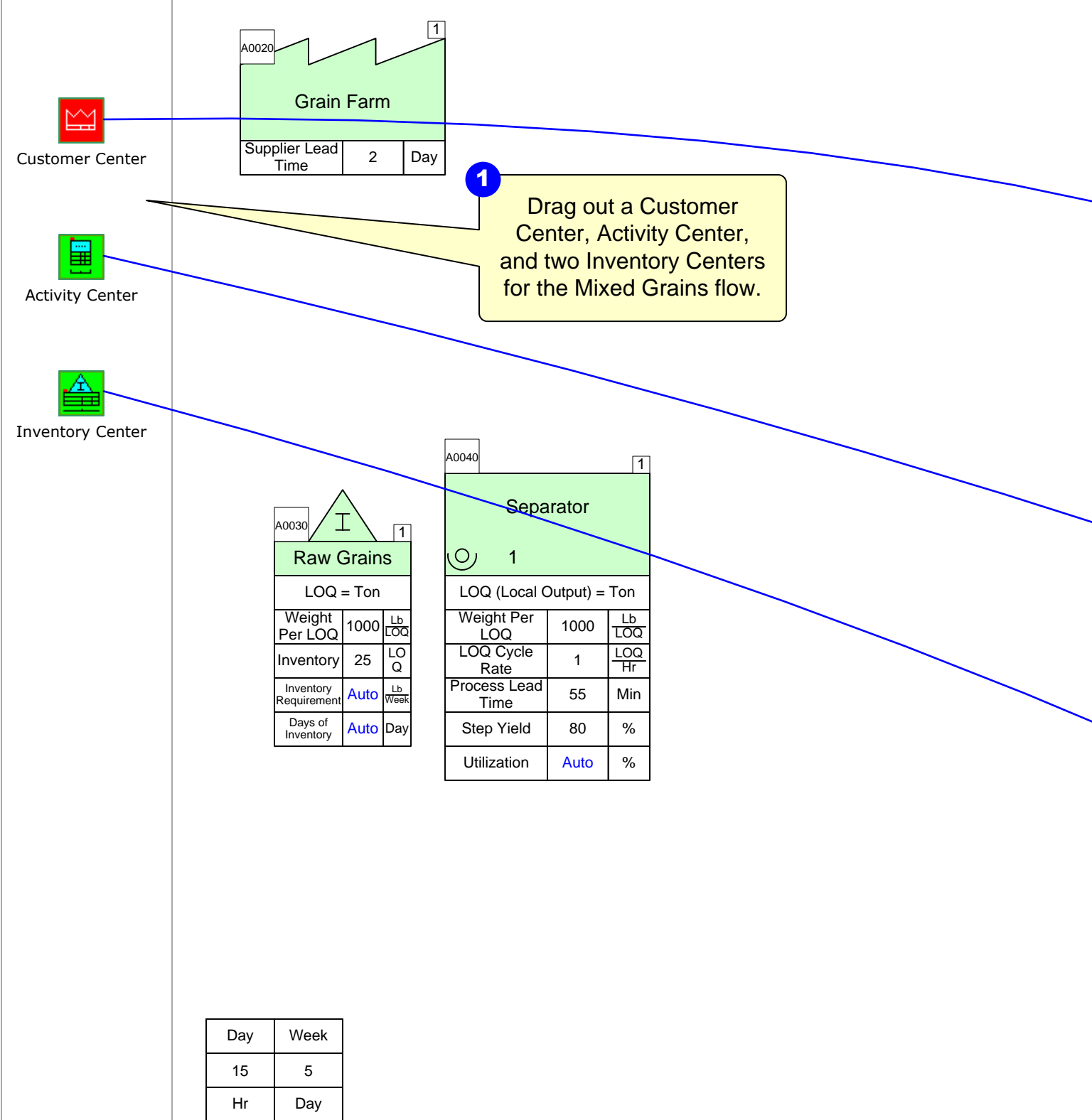

Views Gadgets Update Visualize	Kaizen Properties Kaizen Export Kaizen Import Renumber Kaizens Improve	Map Copy A3 A3 Report Extras	v7 Migrate Spaghetti Event Circle Extras	Help Icon Help Icon Search Stack Help Learn
--	--	--	--	---

A0070		1
Hay		
LOQ = Bale		
Weight Per LOQ	500	Lb/LOQ
Inventory	20	LOQ
Inventory Requirement	Auto	Lb/Week
Days of Inventory	Auto	Day

Z0060		1
Hay Customers		
Demand Weight	10000	Lb/Day
Takt Rate	Auto	Lb/Hr

A0050		1
Grains		
LOQ = Ton		
Weight Per LOQ	1000	Lb/LOQ
Inventory	5	LOQ
Inventory Requirement	Auto	Lb/Week
Days of Inventory	Auto	Day

2 Fill in the data as shown for all shapes.

Z0005		1
Grain Customer		
Demand Weight	1875	Lb/Day
Takt Rate	Auto	Lb/Hr

A0100		1
Mixing		
LOQ (Local Output) = Bag		
Weight Per LOQ	25	Lb/LOQ
LOQ Cycle Rate	15	LOQ/Hr
Process Lead Time	25	Min
Step Yield	100	%
Utilization	Auto	%

A0090		1
Mixed Grain		
LOQ = Bag		
Weight Per LOQ	25	Lb/LOQ
Inventory	105	LOQ
Inventory Requirement	Auto	Lb/Week
Days of Inventory	Auto	Day

Z0080		1
Mixed Grain Customers		
Demand Weight	1250	Lb/Day
Takt Rate	Auto	Lb/Hr

A0110		1
Quinoa		
LOQ = Ton		
Weight Per LOQ	1000	Lb/LOQ
Inventory	1	LOQ
Inventory Requirement	Auto	Lb/Week
Days of Inventory	Auto	Day

-
-
-
-
-
-
-
-
-
-
-
-
-
-
-
-
-

Step 7: Add Arrows

Open	Wall Map	Tag & Paths	Sequence ▾	Select Paths	Check	Show Seq.	Var Solve
List Variables	NUM	Auto Pipe ▾	Auto Path	Auto Tag	Clear	Show Pipes	Solve
Sketch		Sequence			Validate		Calculate

Quick Processing

Sketch Processing

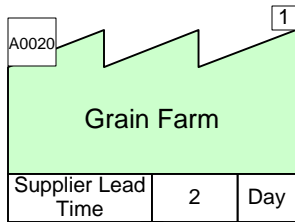

1 Drag out arrows from the Main Stencil as shown to visualize the flow.

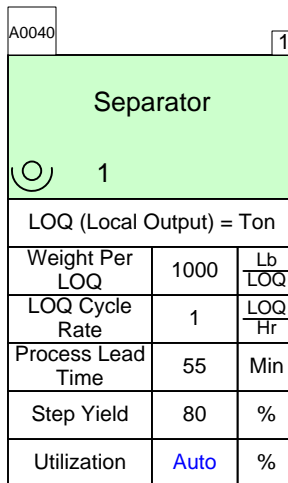
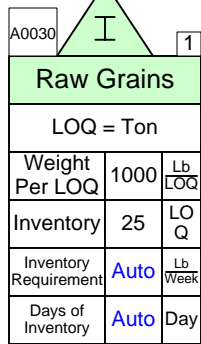

Day	Week
15	5
Hr	Day

Gadgets	Kaizen Export	Map Copy	Spaghetti	Icon Help
Views	Kaizen Import	A3 A3 Report	Event Circle	Icon Search
Visualize	Kaizen Properties	Renumber Kaizens	Migrate	Stack Help
	Improve		Extras	Learn

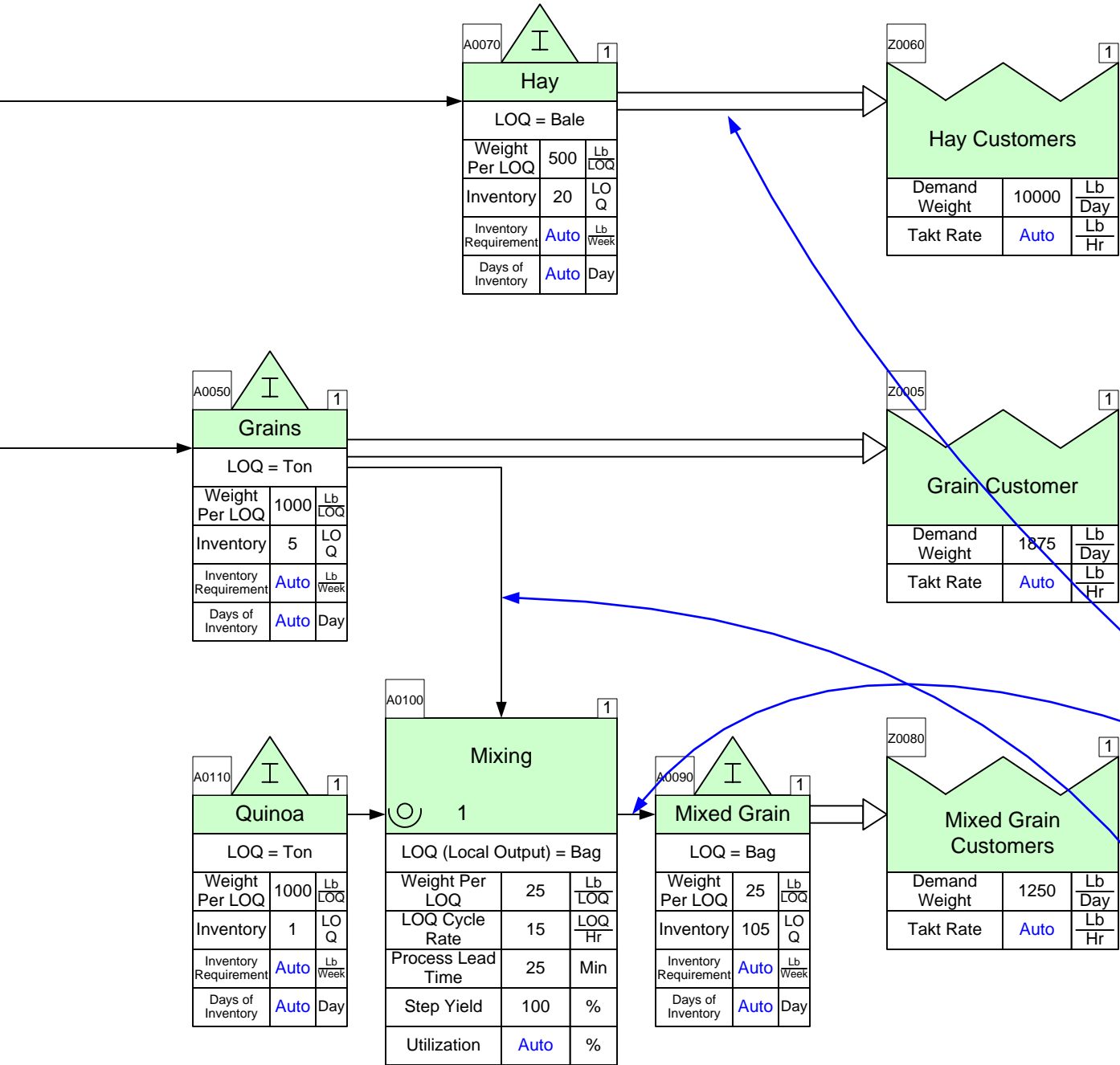

A vertical toolbar on the right side of the interface, containing various icons for map manipulation and simulation. From top to bottom, the icons include: a trash can, a red box, a keyboard, a trash list, a question mark, a red arrow, a curved arrow, a circular arrow, a circular arrow with a plus sign, a curved arrow with a plus sign, a straight arrow, a circular arrow with a plus sign, a curved arrow with a plus sign, a truck, and a scale.

Step 8: Sequence Path 1

Open	Wall Map	Sequence	Select Paths	Check	Show Seq.	Var Solve
List Variables	NUM	Tag & Paths	Auto Pipe	Auto Tag	Show Pipes	Solve
Sketch		Sequence		Validate		Calculate

Quick Processing

Sketch Processing

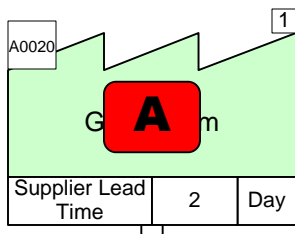

2 Click the Sequence button.

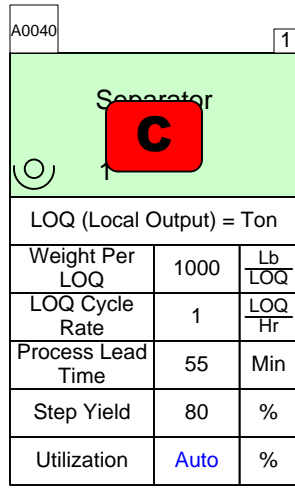

1 Hold down the Shift key and select the green shapes in the order shown. This will be path 1.

Day	Week
15	5
Hr	Day

Gadgets	Kaizen Export	Map Copy	Spaghetti	Icon Help
Views	Kaizen Import	A3 A3 Report	Event Circle	Icon Search
Visualize	Kaizen Properties	Renumber Kaizens	Migrate	Stack Help
	Improve		Extras	Learn

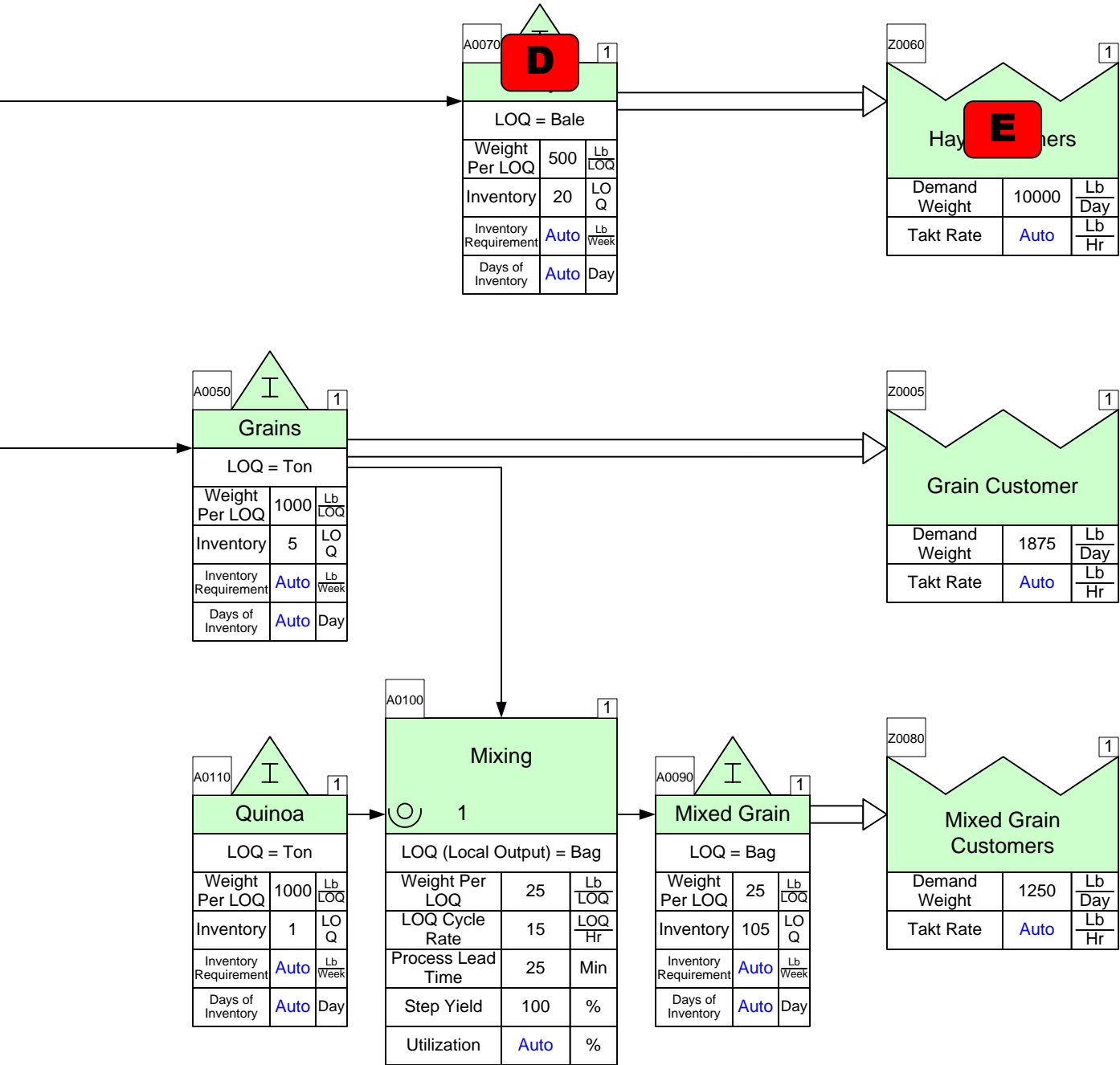

- Home
- Dashboard
- Trash List
- Help
- Navigation icons (arrows, refresh, etc.)
- FIFO+
- Truck icon
- Scale icon

Step 9: Sequence Path 2

Open	Wall Map	Sequence	Select Paths	Check	Show Seq.	Var Solve
NUM	List Variables	Tag & Paths	Auto Pipe	Auto Tag	Show Pipes	Solve
Sketch		Sequence		Validate		Calculate

Quick Processing

Sketch Processing

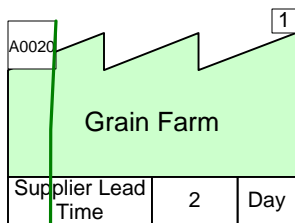

2 Again, hold down the Shift key, select the shapes in order for Path 2, then click the Sequence button.

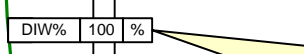

1 These sequence arrows show the first path with the data attached.

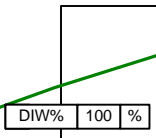
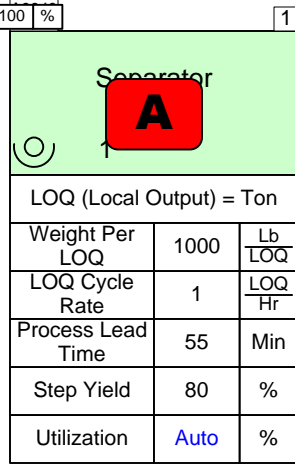
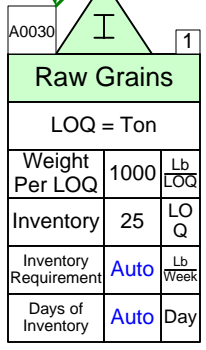

Day	Week
15	5
Hr	Day

Step 10: Sequence Path 3

Open	Wall Map	Sequence	Select Paths	Check	Show Seq.	Var Solve
NUM	List Variables	Tag & Paths	Auto Pipe	Auto Tag	Show Pipes	Solve
Sketch		Sequence		Validate		Calculate

Quick Processing

Sketch Processing

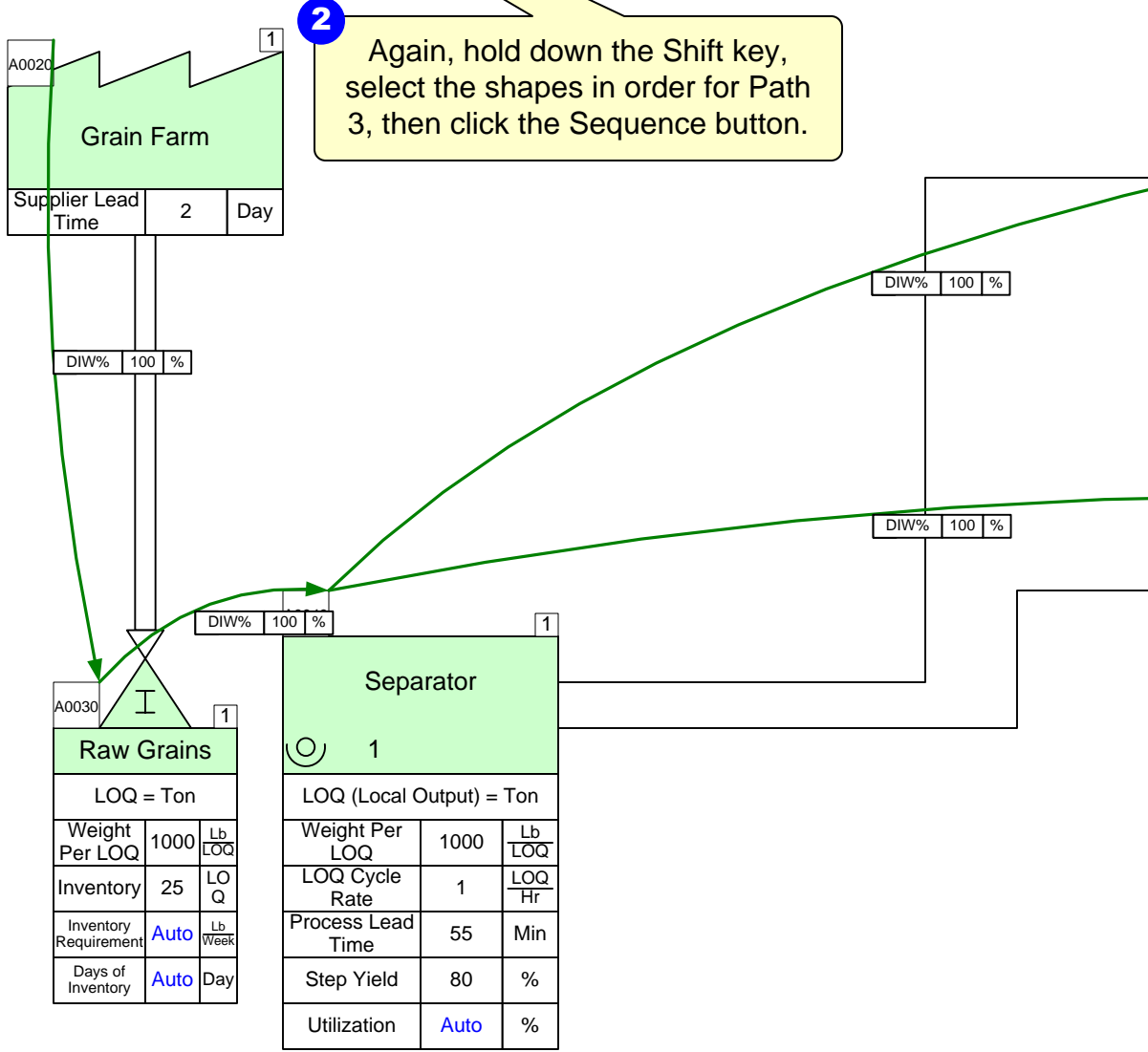

A0020	1
Grain Farm	
Supplier Lead Time	2 Day

DIW%	100	%
------	-----	---

DIW%	100	%
------	-----	---

A0030	1
Raw Grains	
LOQ = Ton	
Weight Per LOQ	1000 $\frac{\text{Lb}}{\text{LOQ}}$
Inventory	25 $\frac{\text{LOQ}}{\text{Q}}$
Inventory Requirement	Auto $\frac{\text{Lb}}{\text{Week}}$
Days of Inventory	Auto Day

1	
Separator	
LOQ (Local Output) = Ton	
Weight Per LOQ	1000 $\frac{\text{Lb}}{\text{LOQ}}$
LOQ Cycle Rate	1 $\frac{\text{LOQ}}{\text{Hr}}$
Process Lead Time	55 Min
Step Yield	80 %
Utilization	Auto %

DIW%	100	%
------	-----	---

DIW%	100	%
------	-----	---

Day	Week
15	5
Hr	Day

Gadgets	Kaizen Export	Map Copy	Spaghetti	Icon Help
Views	Kaizen Import	A3 A3 Report	Event Circle	Icon Search
Visualize	Kaizen Properties	Renumber Kaizens	Migrate	Stack Help
	Improve		Extras	Learn

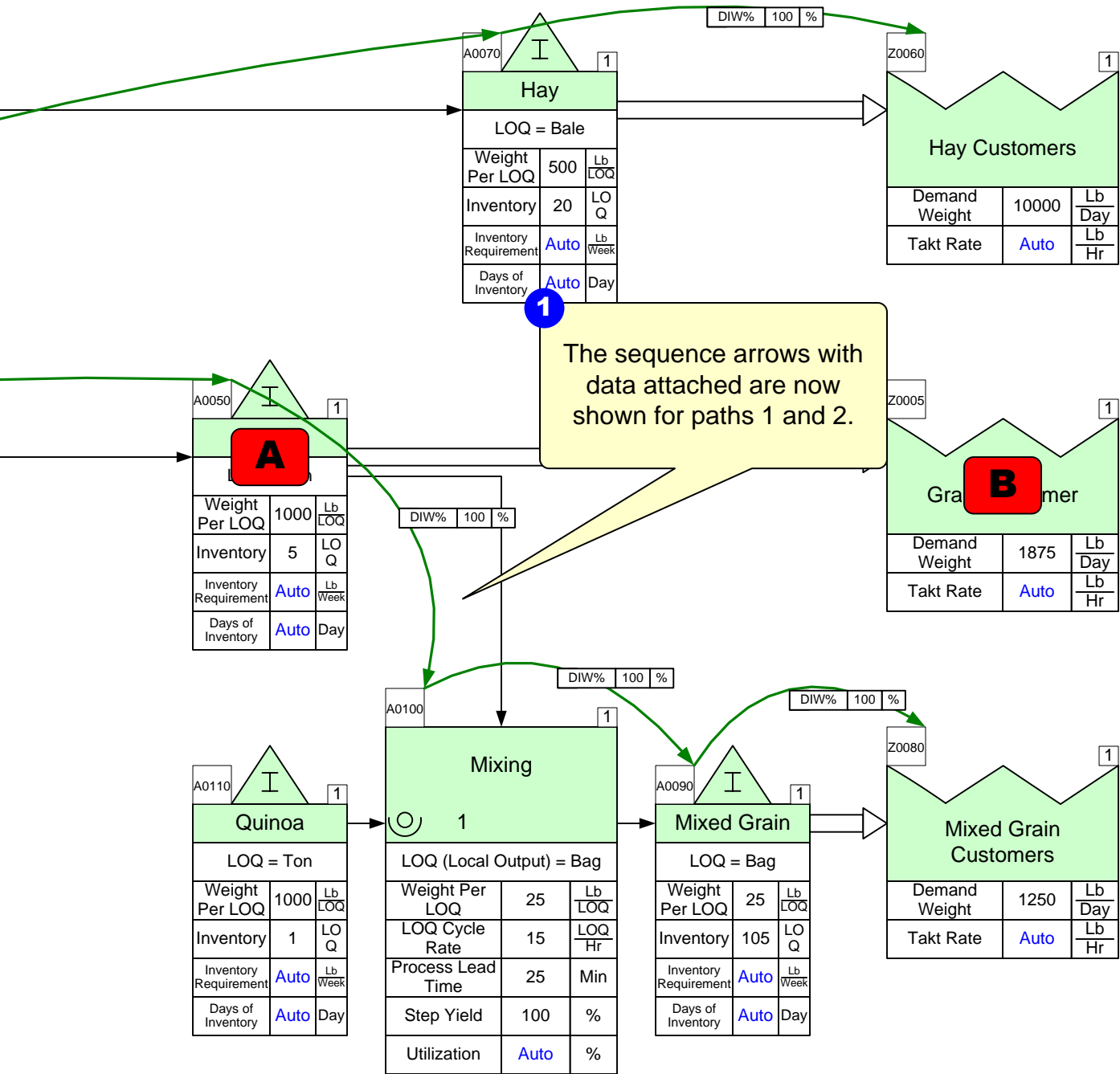

The sequence arrows with data attached are now shown for paths 1 and 2.

Step 11: Sequence Path 4

Open	Wall Map	Sequence	Select Paths	Check	Show Seq.	Var Solve
NUM	List Variables	Tag & Paths	Auto Pipe	Auto Tag	Show Pipes	Solve
Sketch		Sequence		Validate		Calculate

Quick Processing

Sketch Processing

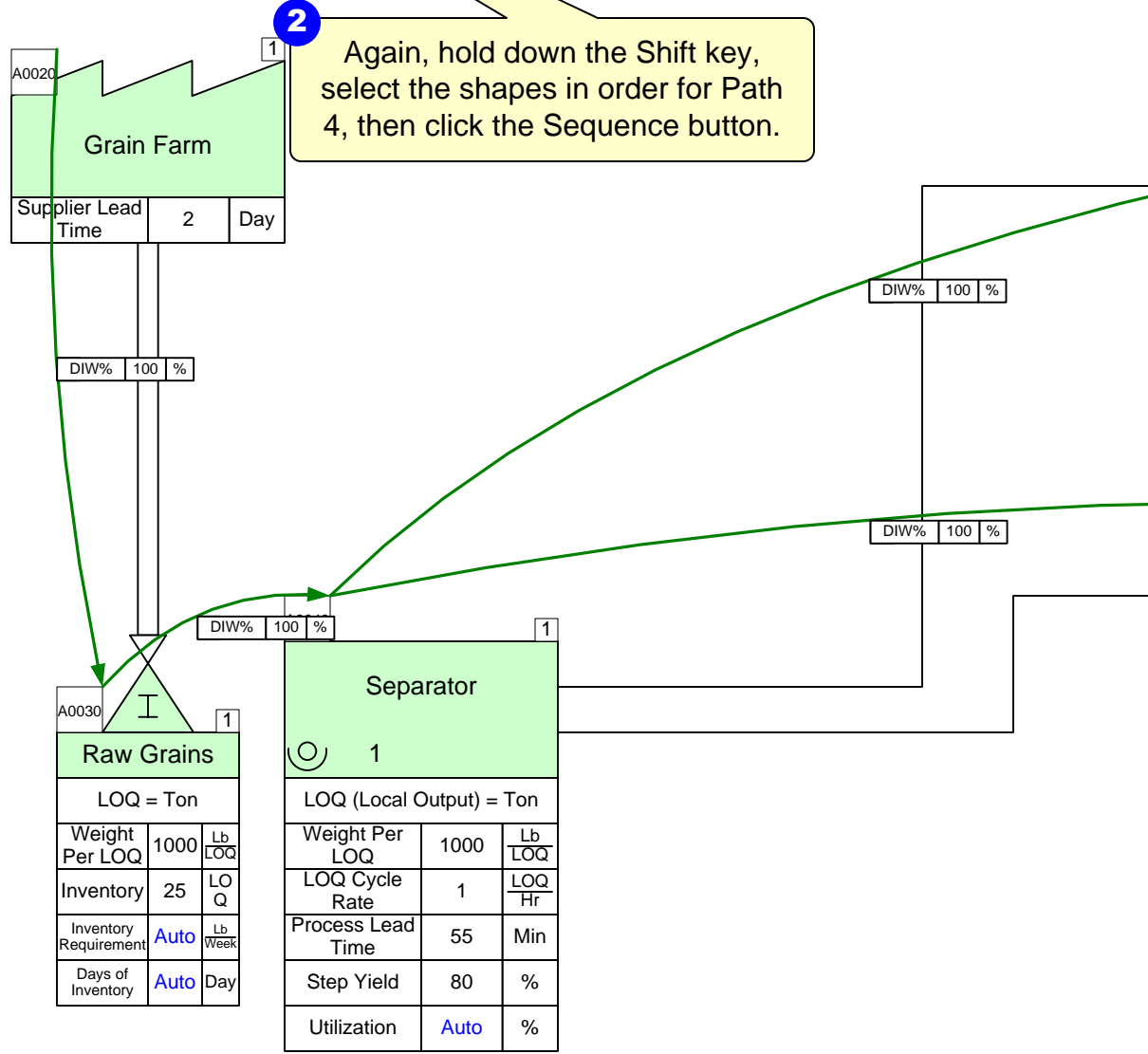

A0020	1
Grain Farm	
Supplier Lead Time	2 Day

A0030	1
Raw Grains	
LOQ = Ton	
Weight Per LOQ	1000 Lb LOQ
Inventory	25 LO Q
Inventory Requirement	Auto Lb Week
Days of Inventory	Auto Day

1	
Separator	
LOQ (Local Output) = Ton	
Weight Per LOQ	1000 Lb LOQ
LOQ Cycle Rate	1 LOQ Hr
Process Lead Time	55 Min
Step Yield	80 %
Utilization	Auto %

Day	Week
15	5
Hr	Day

Gadgets	Kaizen Export	Map Copy	Spaghetti	Icon Help
Views	Kaizen Import	A3 A3 Report	Event Circle	Icon Search
Visualize	Kaizen Properties	Renumber Kaizens	Migrate	Stack Help
	Improve		Extras	Learn

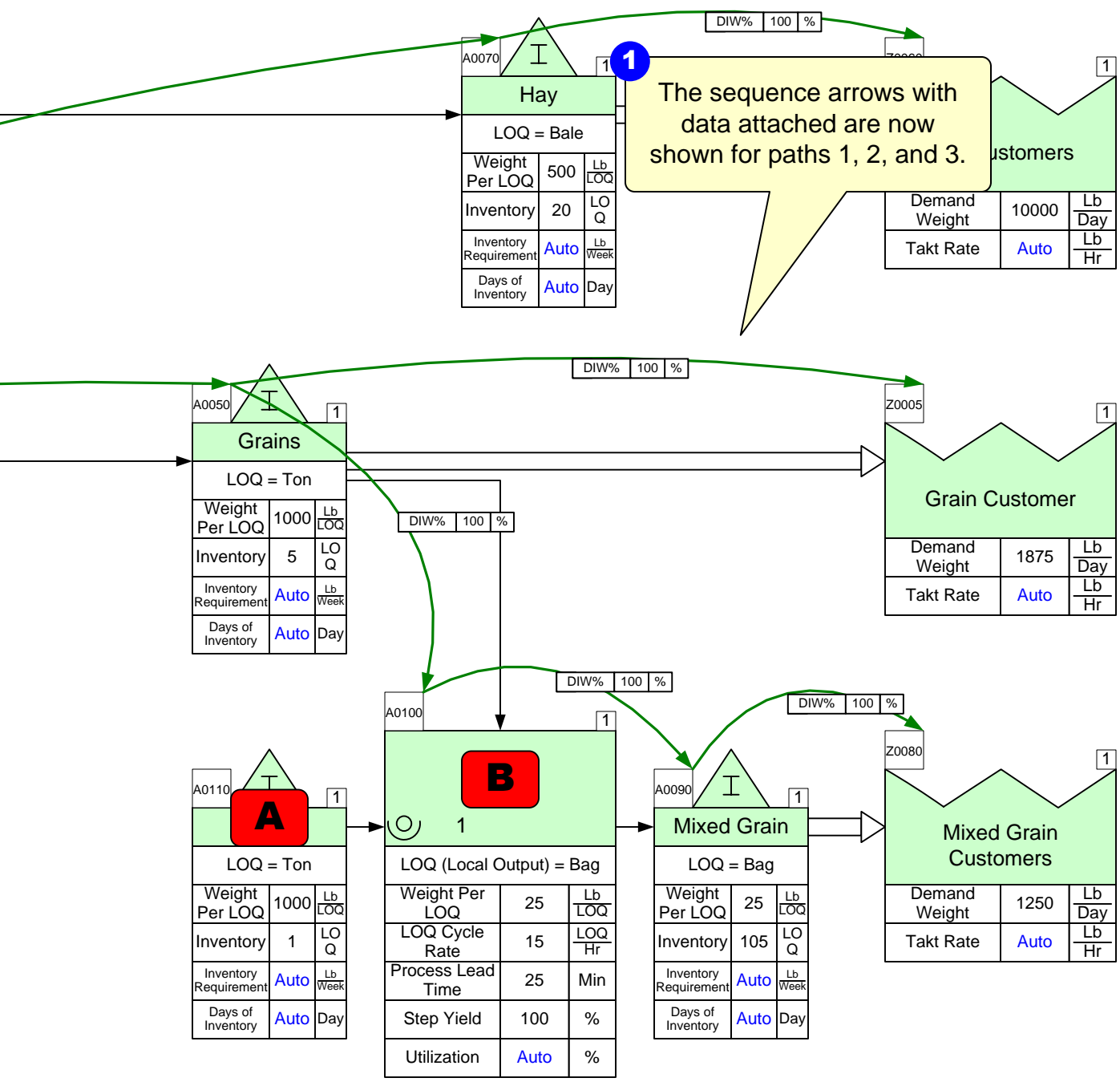

- Home
- Print
- TASK LIST
- Help
- Navigation icons (back, forward, search, etc.)
- Process icons (truck, scale, etc.)
- FIFO+
- Truck icon
- Scale icon

Step 12: Create Path Numbers Based on Sequence Arrows

Open	Wall Map	Sequence	Select Paths	+	Show Seq.	Var Solve
NUM	List Variables	Tag & Paths	Auto Pipe	Auto Tag	Show Pipes	Solve
Sketch	Sequence	Auto Path	Check	Clear	Calculate	

2 Click Auto Path to automatically generate path numbers based on the sequence arrows.

3 Click Auto Tag to automatically re-order the tag numbers based on the sequence arrows.

4 After clicking Auto Path, the path numbers are added.

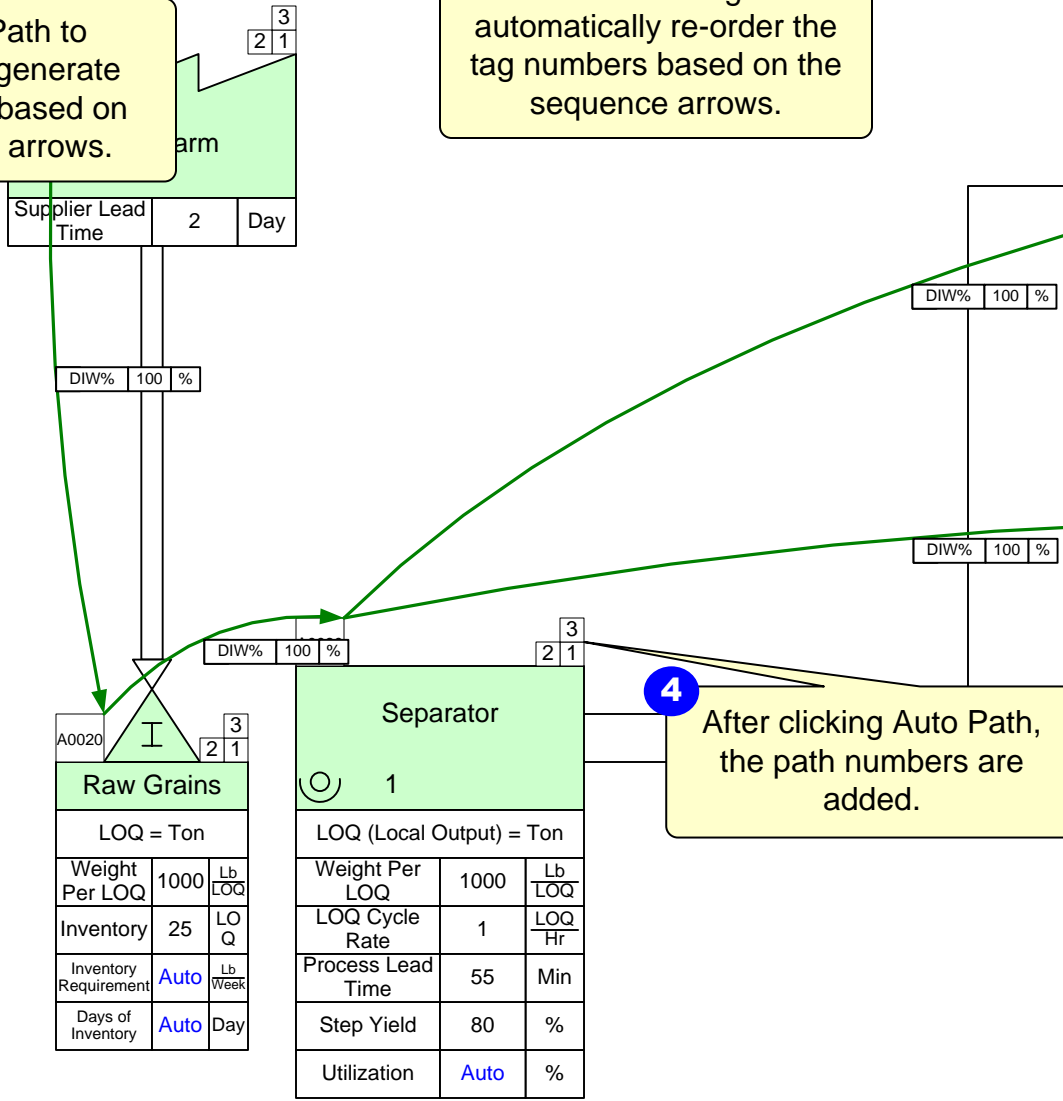

NOTE: Your path numbers may be different than shown but the calculations will still be correct.

Day	Week
15	5
Hr	Day

Gadgets	Kaizen Export	Map Copy	Spaghetti	Icon Help
Views	Kaizen Import	A3 Report	Event Circle	Icon Search
Visualize	Kaizen Properties	Renumber Kaizens	Migrate	Stack Help
	Improve		Extras	Learn

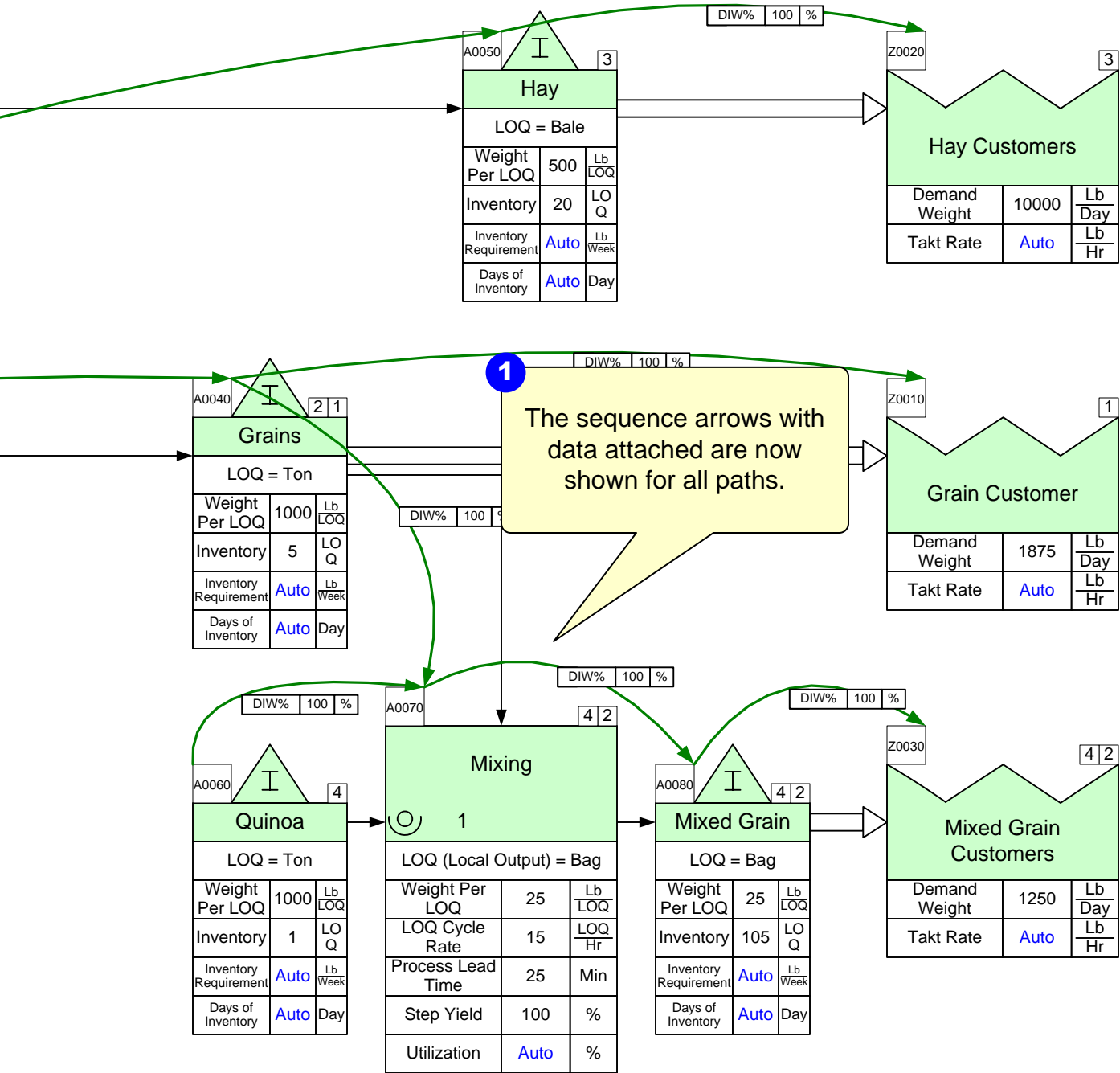

- Home
- Print
- Trash List
- Help
- Navigation icons: back, forward, search, refresh, undo, redo, zoom in, zoom out, pan, etc.
- FIFO+
- Truck icon
- Scale icon

Step 13: Update Sequence Data

Open	Wall Map	Sequence ▾	Select Paths	Show Seq.	Var Solve
NUM	List Variables	Tag & Paths	Auto Pipe ▾	Show Pipes	Solve
Sketch		Auto Path	Auto Tag	Clear	Calculate
		Sequence		Validate	

Quick Processing

Sketch Processing

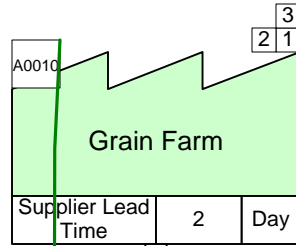

DIW%	100	%
------	-----	---

DIW%	100	%
------	-----	---

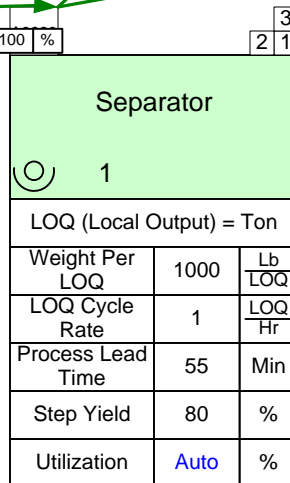
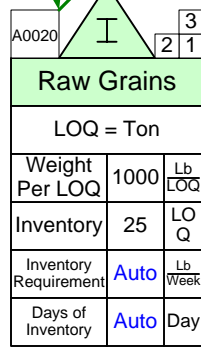

DIW%	100	%
------	-----	---

DIW%	100	%
------	-----	---

3 The Sequence Arrows can be hidden or shown by clicking the Show Sequence button. To simplify the map, the arrows will now be hidden.

Day	Week
15	5
Hr	Day

Gadgets	Kaizen Export	Map Copy	Spaghetti	Icon Help
Views	Kaizen Import	A3 Report	Event Circle	Icon Search
Visualize	Kaizen Properties	Renumber Kaizens	Migrate	Stack Help
	Improve		Extras	Learn

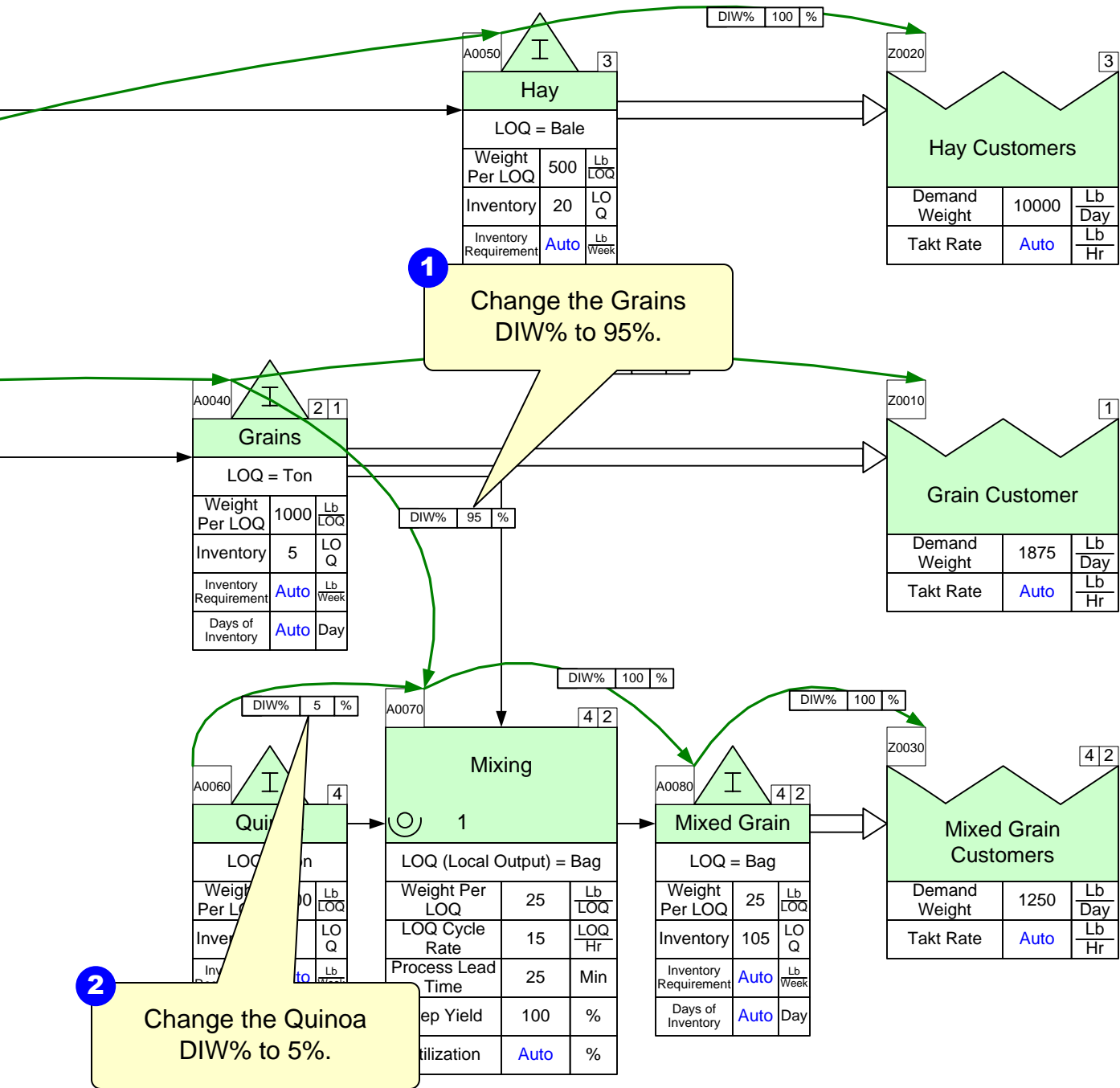

- Home
- Print
- Trash List
- Help
- Navigation icons (back, forward, search, etc.)
- Simulation icons (play, stop, refresh, etc.)
- FIFO+
- Truck icon
- Scale icon

Step 14: Add-Ons

Open	Wall Map	Sequence ▾	Select Paths	Check	Show Seq.	Var Solve
List Variables	NUM	Auto Pipe ▾	Auto Tag	Clear	Show Pipes	Solve
Sketch		Sequence		Validate		Calculate

Quick Processing

Sketch Processing

Activity Center

Activity Scrap

Activity Setup

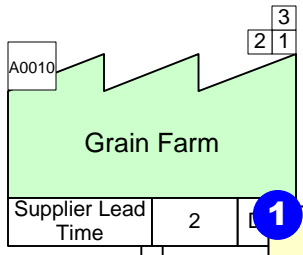

1

Note how all these yellow add-on names start with the word "Activity." Yellow Add-ons that follow a green Center can only be used with that Center. So, these "Activity..." add-ons can be used only with the Activity Center.

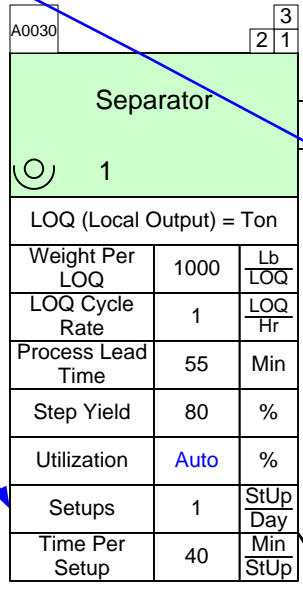
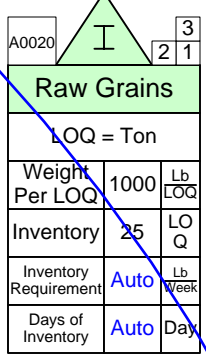

2

Enter the setup time for the "Separator" activity.

Day	Week
15	5
Hr	Day

Gadgets	Kaizen Export	Map Copy	Spaghetti	Icon Help
Views	Kaizen Import	A3 A3 Report	Event Circle	Icon Search
Visualize	Kaizen Properties	Renumber Kaizens	Migrate	Stack Help
	Improve		Extras	Learn

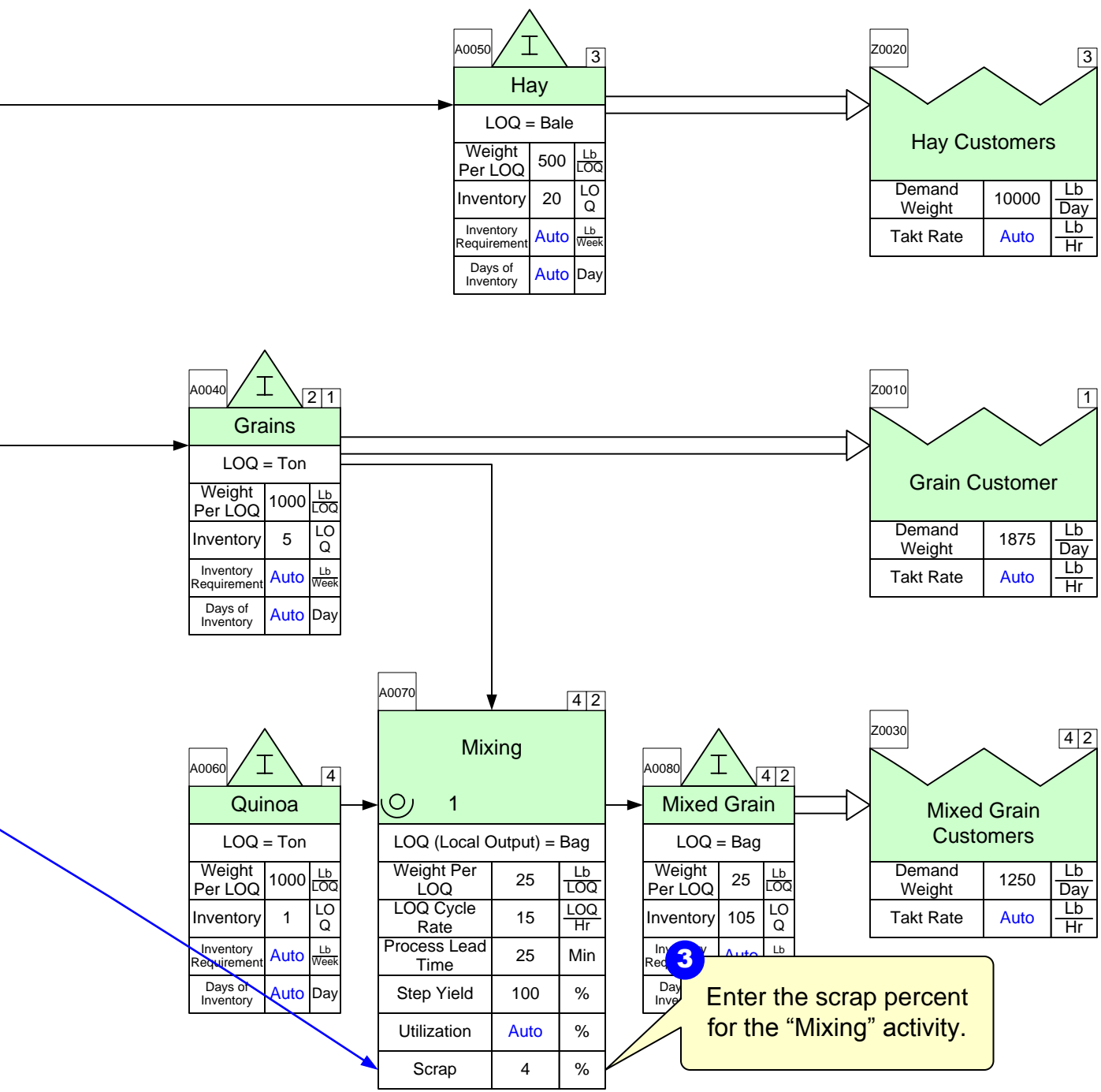

3 Enter the scrap percent for the "Mixing" activity.

Step 15: Add Arrow Data

Wall Map	Sequence ▾	Select Paths	Show Seq.	Var Solve
Open	Auto Pipe ▾	Auto Tag	Show Pipes	Solve
List Variables	Auto Path		Clear	
Sketch	Sequence		Validate	Calculate

Quick Processing

Sketch Processing



Sequence Center



Sequence Output Weight

A0010			3
			2 1
Grain Farm			
Supplier Lead Time	2	Day	

DIW%	100	%
------	-----	---

A0020			3
			2 1
Raw Grains			
LOQ = Ton			
Weight Per LOQ	1000	Lb LOQ	
Inventory	25	LO Q	
Inventory Requirement	Auto	Lb Week	
Days of Inventory	Auto	Day	

			3
			2 1
Separator			
1			
LOQ (Local Output) = Ton			
Weight Per LOQ	1000	Lb LOQ	
LOQ Cycle Rate	1	LOQ Hr	
Process Lead Time	55	Min	
Step Yield	80	%	
Utilization	Auto	%	
Setups	1	StUp Day	
Time Per Setup	40	Min StUp	

DIW%	100	%
UOW%	20	%
Cost Allocation	96	%

1 Click the Show Seq button on the toolbar to show the Sequence Arrows again.

2 Drag out a Sequence Output Weight add-on and glue it under the DIW% from Separator to Grains and Separator to Hay.

Day	Week
15	5
Hr	Day

4 To create more room, select the Sequence Arrow and use the yellow diamond to change the curvature of the arrow.

3 Enter cost allocations and UOW% for both add-ons.

DIW%	100	%
UOW%	80	%
Cost Allocation	4	%

A0050	I	3
Hay		
LOQ = Bale		
Weight Per LOQ	500	Lb LOQ
Inventory	20	LO Q
Inventory Requirement	Auto	Lb Week
Days of Inventory	Auto	Day

Z0020	3	
Hay Customers		
Demand Weight	10000	Lb Day
Takt Rate	Auto	Lb Hr

A0040	I	2 1
Grains		
LOQ = Ton		
Weight Per LOQ	1000	Lb LOQ
Inventory	5	LO Q
Inventory Requirement	Auto	Lb Week
Days of Inventory	Auto	Day

Z0010	1	
Grain Customer		
Demand Weight	1875	Lb Day
Takt Rate	Auto	Lb Hr

A0060	I	4
Quinoa		
LOQ = Ton		
Weight Per LOQ	1000	Lb LOQ
Inventory	1	LO Q
Inventory Requirement	Auto	Lb Week
Days of Inventory	Auto	Day

A0070	4 2	
Mixing		
LOQ (Local Output) = Bag		
Weight Per LOQ	25	Lb LOQ
LOQ Cycle Rate	15	LOQ Hr
Process Lead Time	25	Min
Step Yield	100	%
Utilization	Auto	%
Scrap	4	%

A0080	I	4 2
Mixed Grain		
LOQ = Bag		
Weight Per LOQ	25	Lb LOQ
Inventory	105	LO Q
Inventory Requirement	Auto	Lb Week
Days of Inventory	Auto	Day

Z0030	4 2	
Mixed Grain Customers		
Demand Weight	1250	Lb Day
Takt Rate	Auto	Lb Hr

Step 16: Add Resource Centers

Wall Map	Sequence ▾	Select Paths	Show Seq.	Var Solve
Open	Auto Pipe ▾	Auto Tag	Show Pipes	Solve
List Variables	Auto Path		Clear	
Sketch	Sequence	Validate	Calculate	

Quick Processing
 Sketch Processing

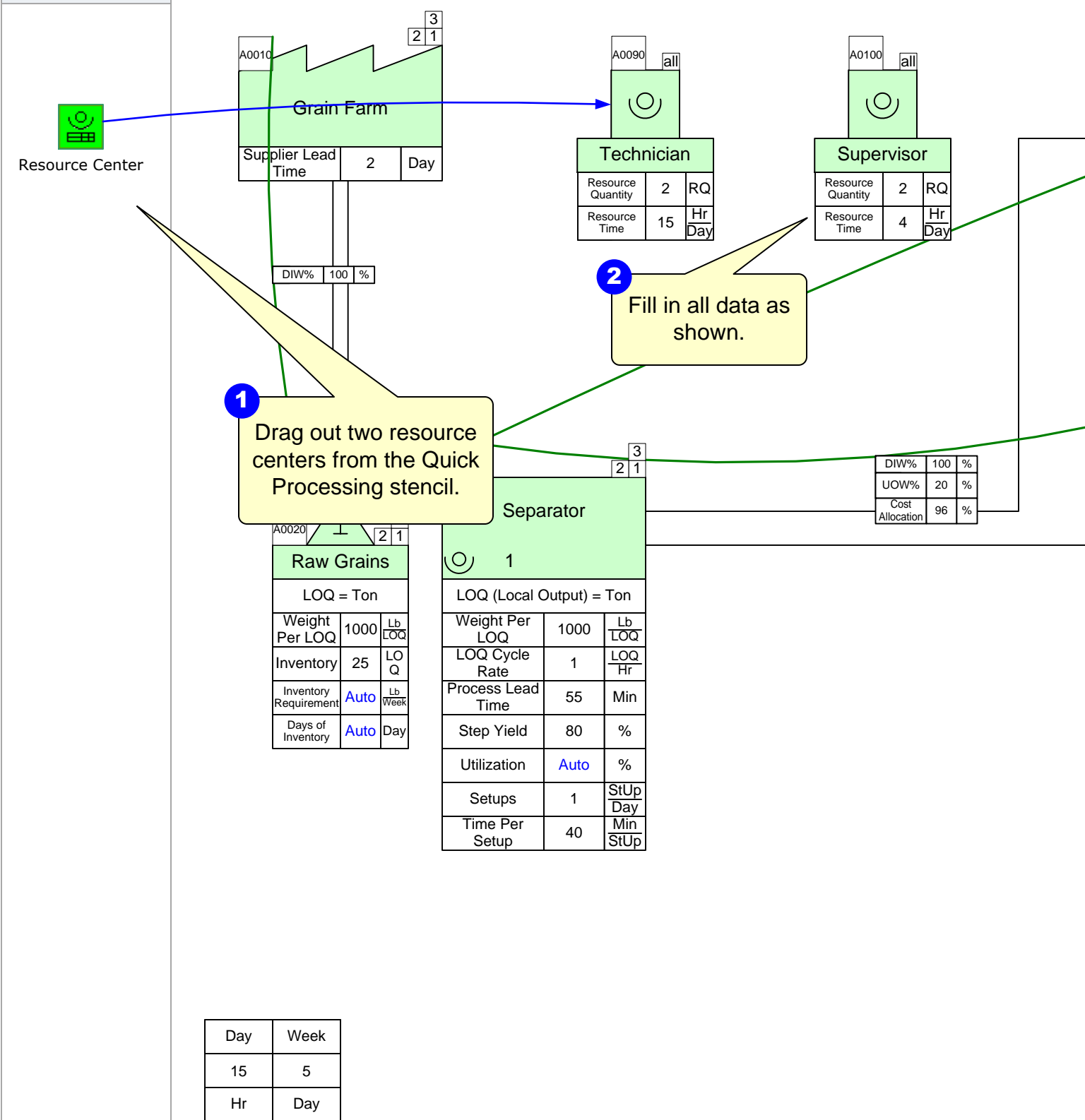

Step 17: Add Resource Pipes

Wall Map NUM List Variables Sketch	Sequence ▾ Auto Pipe ▾ Auto Path Sequence	Select Paths Auto Tag Check Validate	Show Seq. Show Pipes Clear Calculate	Var Solve Solve
---	--	---	---	--------------------

Quick Processing

Sketch Processing

Resource Pipe

1

Drag out Resource Pipes from the Quick Processing stencil to show how the resources are allocated.

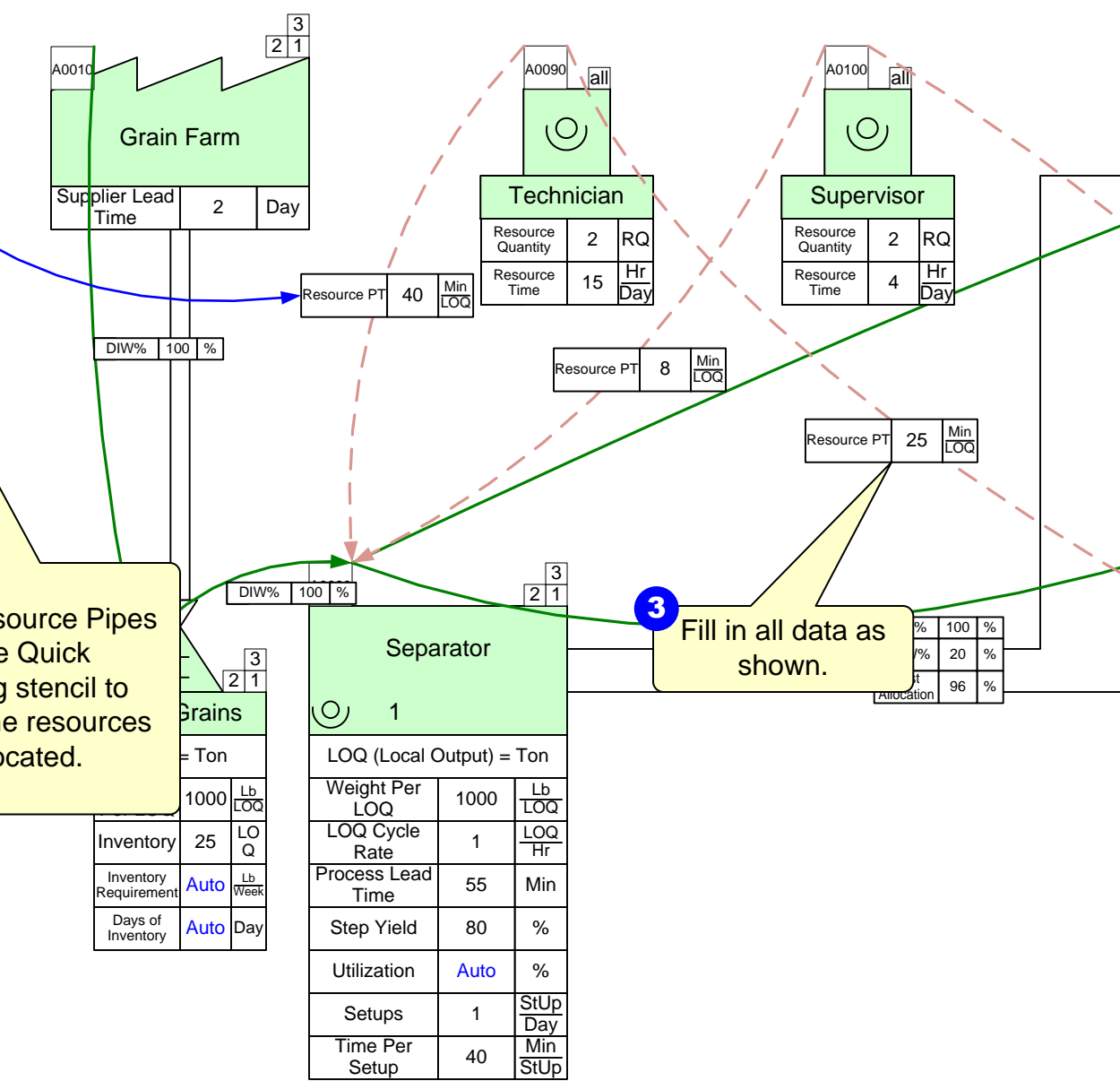

3

Fill in all data as shown.

Day	Week
15	5
Hr	Day

Step 18: Solve the model

Wall Map	Sequence ▾	Select Paths	Check	Show Seq.	Var Solve
Open	Auto Pipe ▾	Auto Tag	Clear	Show Pipes	Solve
List Variables	Auto Path			Validate	Calculate
Sketch		Sequence		Calculate	

Quick Processing

Sketch Processing

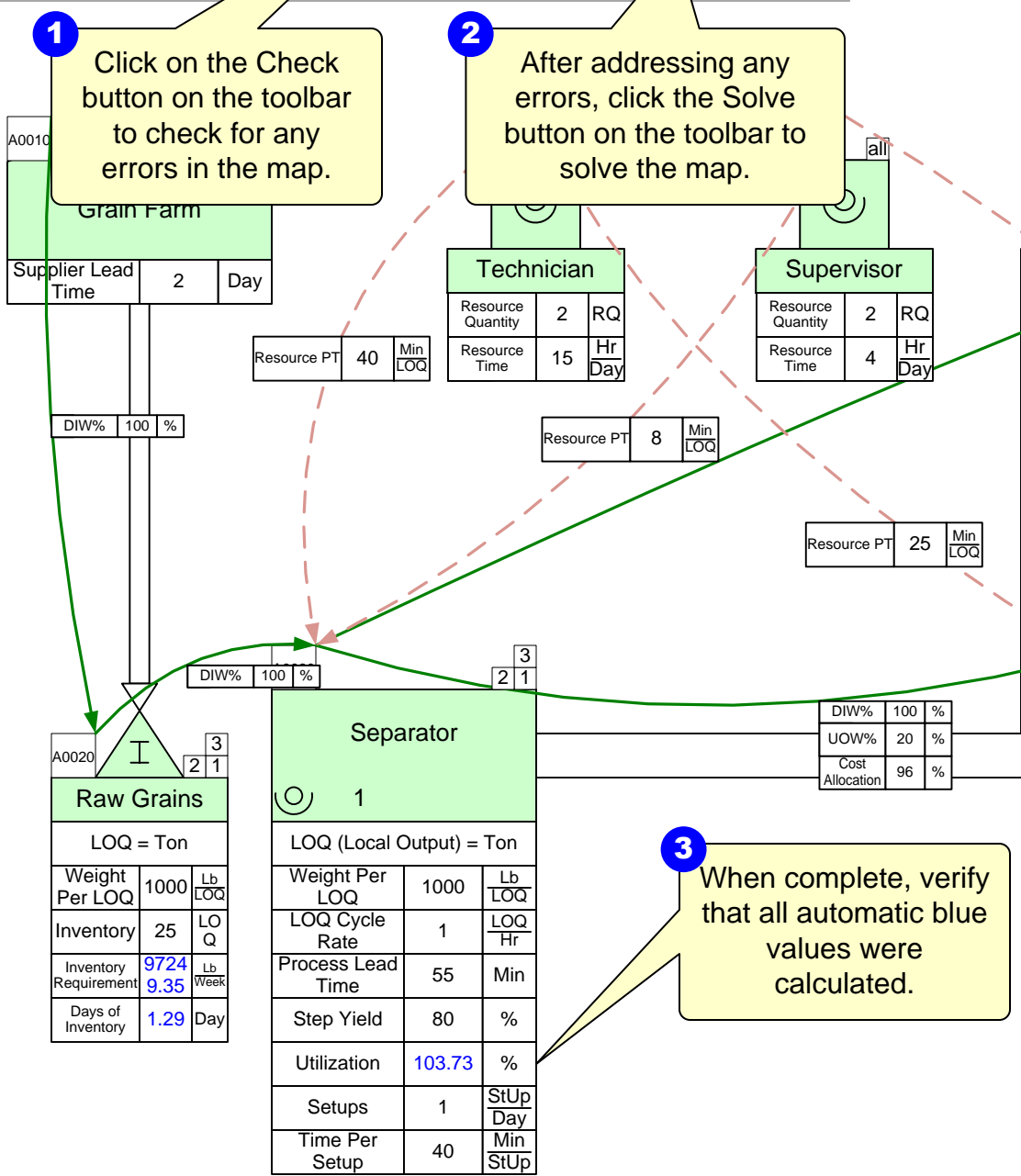

A0010		
Grain Farm		
Supplier Lead Time	2	Day

Technician		
Resource Quantity	2	RQ
Resource Time	15	Hr Day

Supervisor		
Resource Quantity	2	RQ
Resource Time	4	Hr Day

Resource PT	40	Min LOQ
-------------	----	---------

Resource PT	8	Min LOQ
-------------	---	---------

Resource PT	25	Min LOQ
-------------	----	---------

DIW%	100	%
------	-----	---

DIW%	100	%
------	-----	---

A0020		
Raw Grains		
LOQ = Ton		
Weight Per LOQ	1000	Lb LOQ
Inventory	25	LO Q
Inventory Requirement	9724	Lb Week
Days of Inventory	1.29	Day

A0020		
Separator		
LOQ (Local Output) = Ton		
Weight Per LOQ	1000	Lb LOQ
LOQ Cycle Rate	1	LOQ Hr
Process Lead Time	55	Min
Step Yield	80	%
Utilization	103.73	%
Setups	1	StUp Day
Time Per Setup	40	Min StUp

DIW%	100	%
UOW%	20	%
Cost Allocation	96	%

Day	Week
15	5
Hr	Day

Gadgets	Kaizen Export	Map Copy	Spaghetti	Icon Help
Views	Kaizen Import	A3 Report	Event Circle	Icon Search
Visualize	Kaizen Properties	Renumber Kaizens	Migrate	Stack Help
	Improve		Extras	Learn

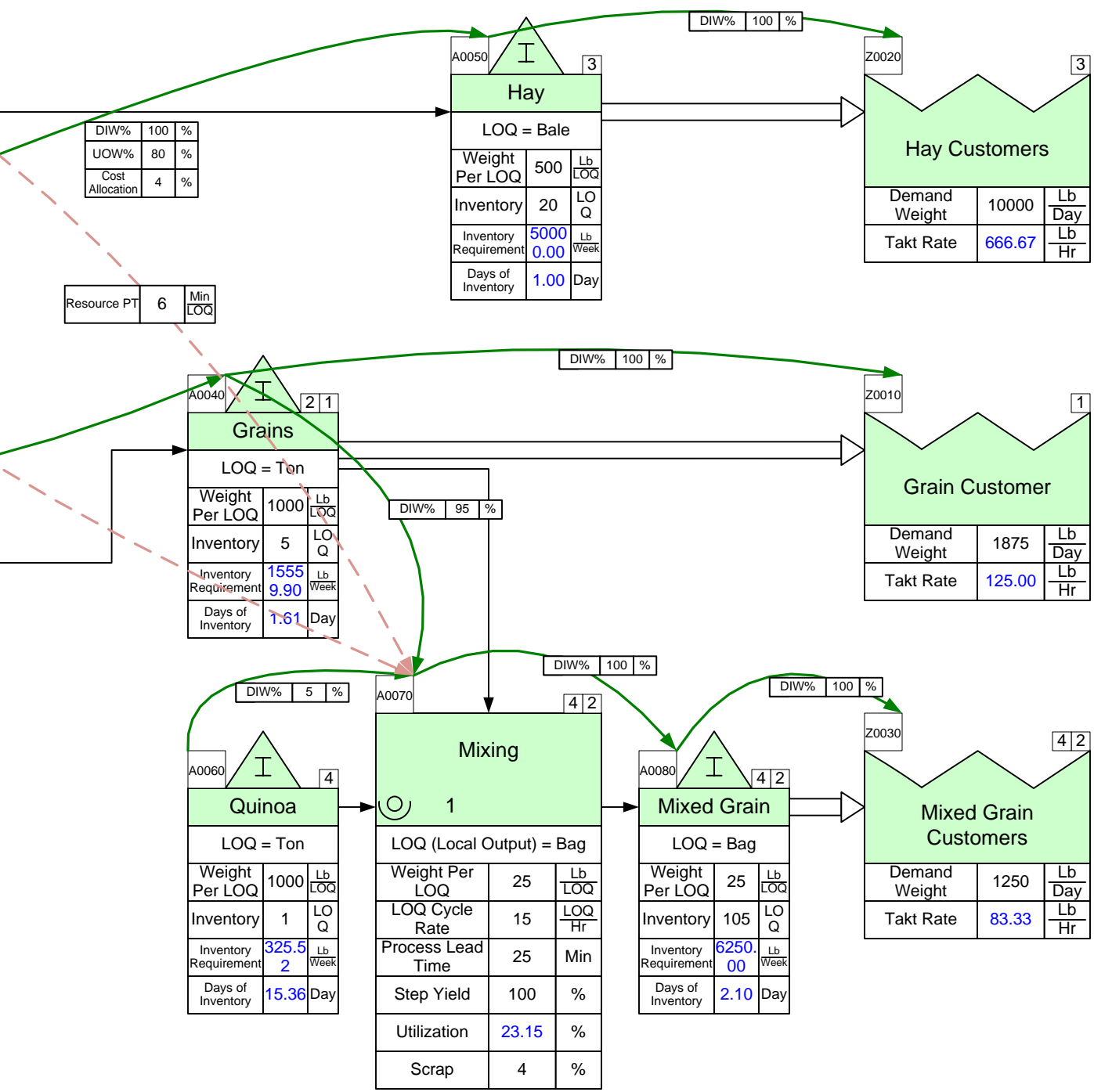

Resource PT	6	Min LOQ
-------------	---	---------

- Home
- Print
- Trash List
- Help
- Navigation icons (back, forward, search, etc.)
- Simulation control icons (start, stop, refresh, etc.)
- FIFO+
- Truck icon
- Scale icon

Step 19: Add Lead Time Chart

Wall Map	Sequence	Select Paths	Show Seq.	Var Solve
NUM	Auto Pipe	Auto Tag	Show Pipes	Solve
List Variab	Tag &		Clear	Calculate
Sketch			Validate	

1 Drag out a Lead Time Chart from the Quick Processing stencil.

2 Right-click on the chart shape and select "Plot Ladder Chart".

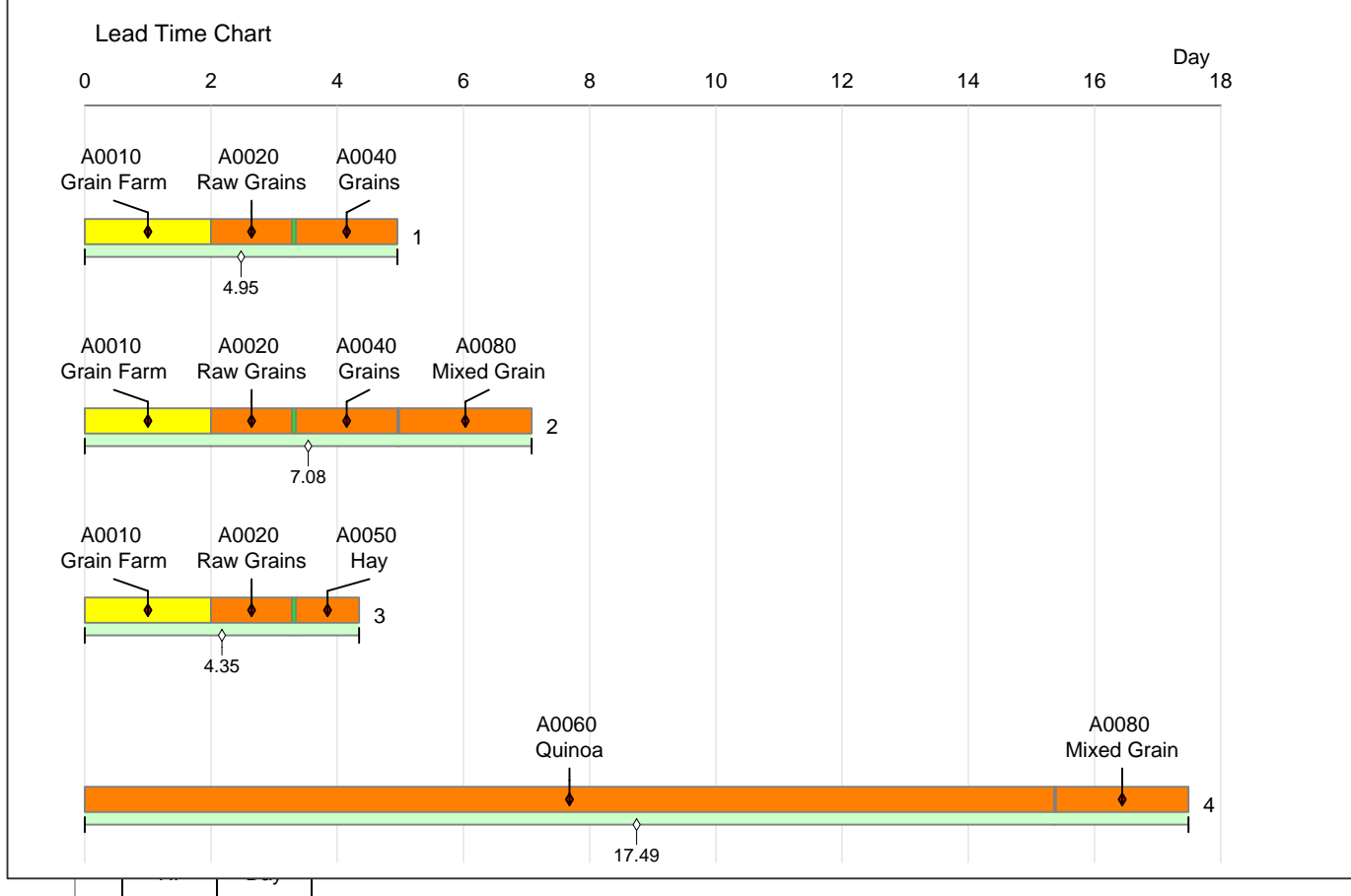
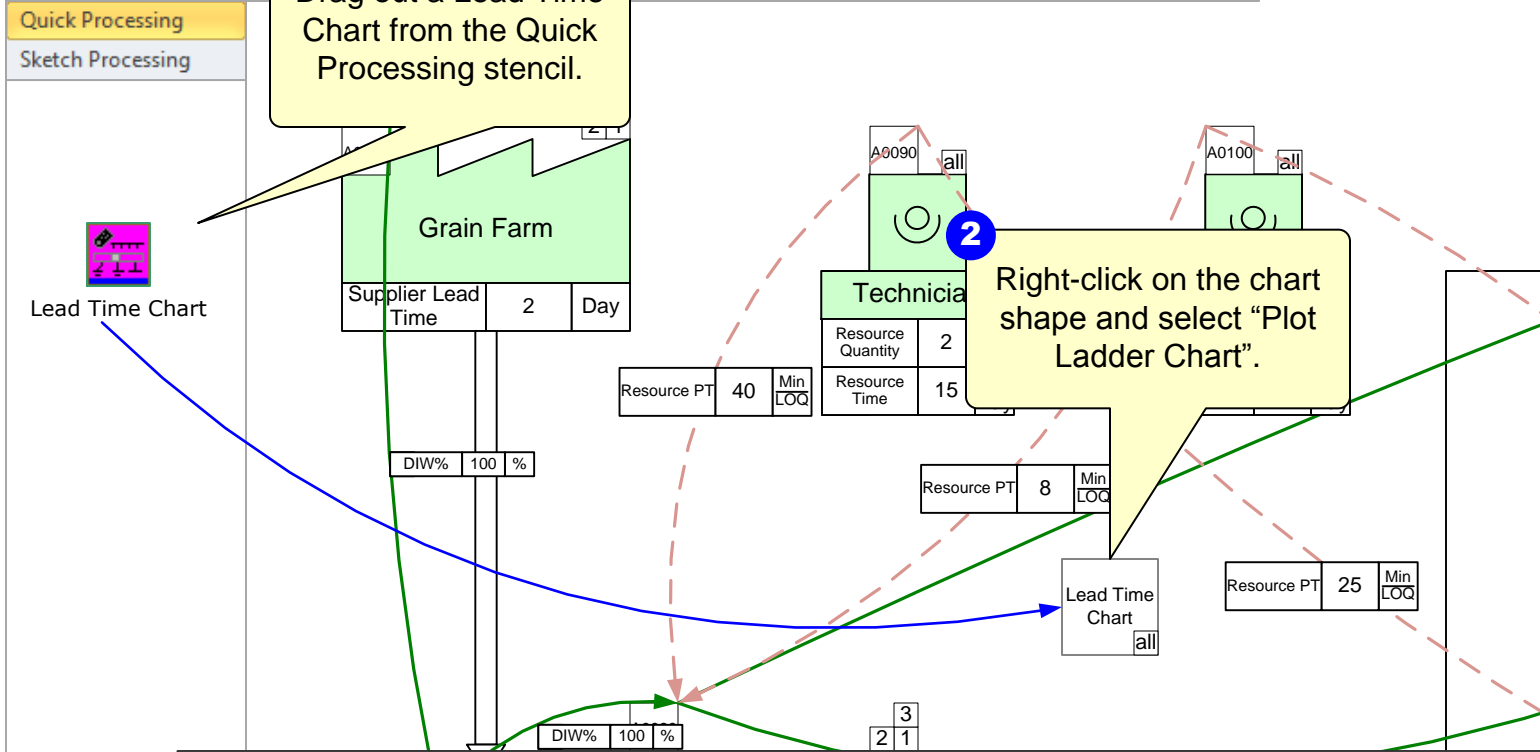

Gadgets	Kaizen Export	Map Copy	Spaghetti	Icon Help
Views	Kaizen Import	A3 A3 Report	Event Circle	Icon Search
Visualize	Kaizen Properties	Renumber Kaizens	Migrate	Stack Help
	Improve		Extras	Learn

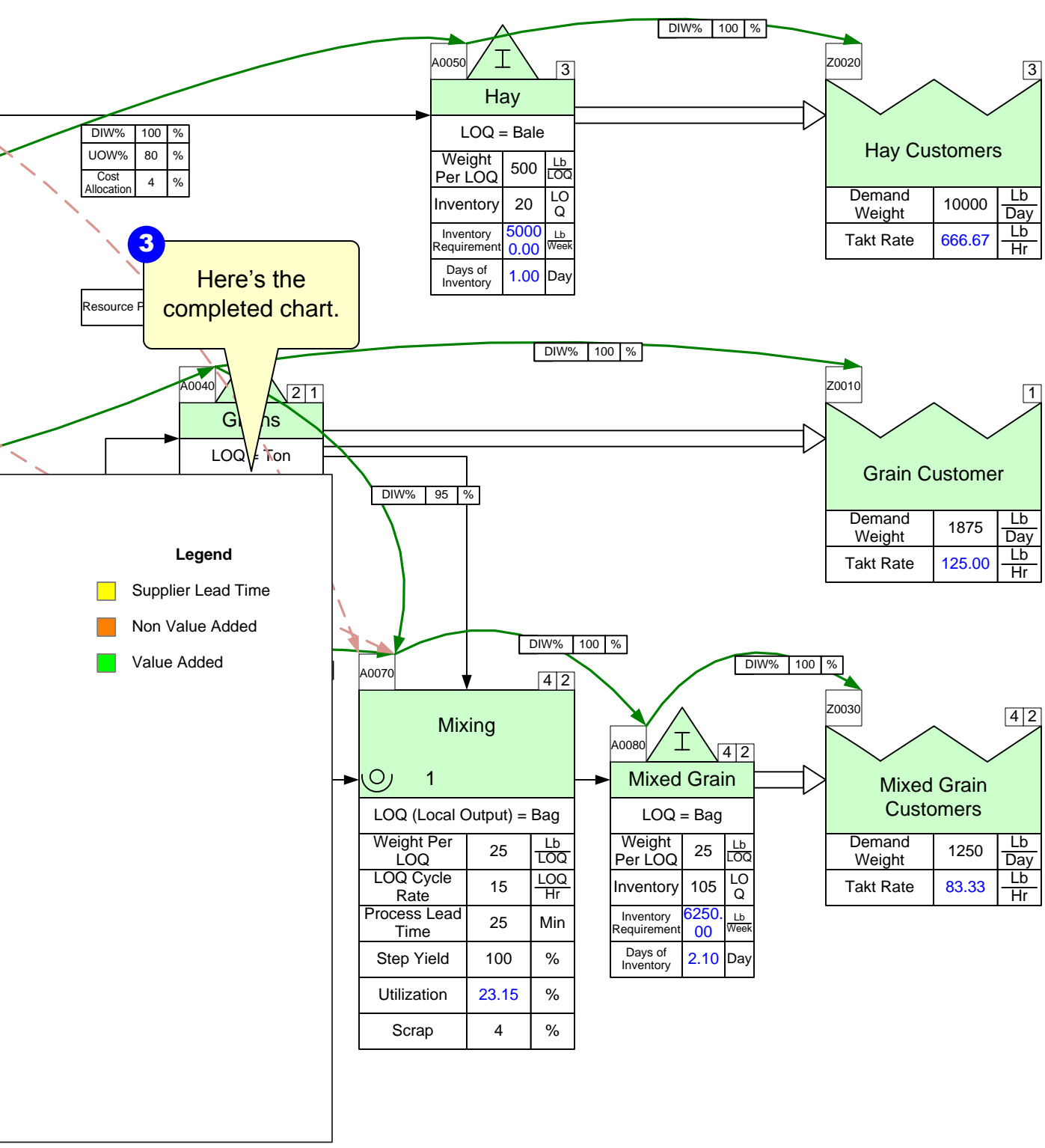

- Home
- Print
- Trash List
- Help
- Navigation icons (back, forward, search, etc.)
- Process icons (truck, factory, etc.)

Step 20: Add Resource Balance Chart

Wall Map	Sequence ▾	Select Paths	Show Seq.	Var Solve
Open	Auto Pipe ▾	Auto Tag	Show Pipes	Solve
List Variables	Tag & Paths	Auto Path	Clear	
Sketch	Sequence	Validate	Calculate	

Quick Processing

Sketch Processing

Resource Balance Chart

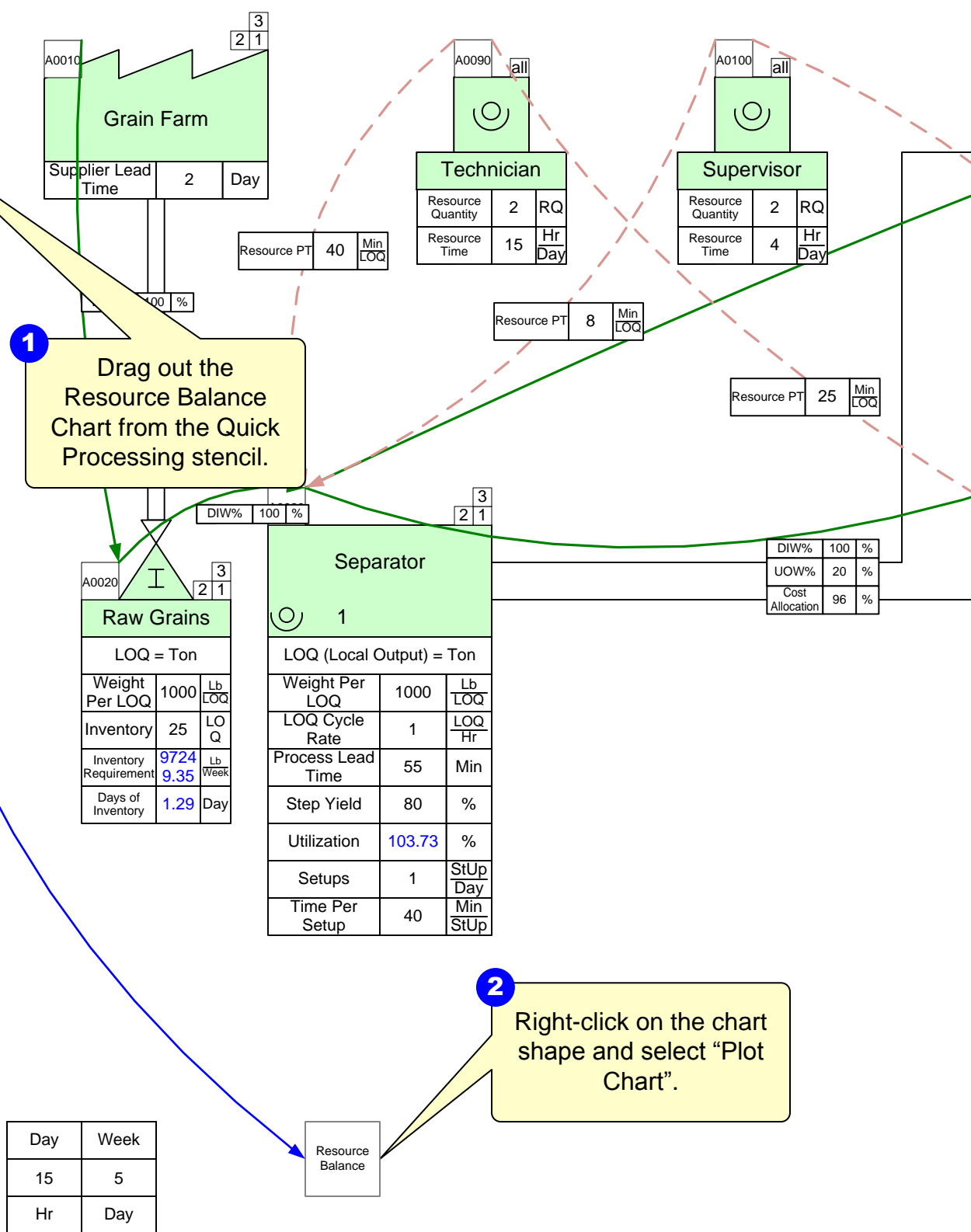

Gadgets	Kaizen Export	Map Copy	Spaghetti	Icon Help
Views	Kaizen Import	A3 Report	Event Circle	Icon Search
Visualize	Kaizen Properties	Renumber Kaizens	Migrate	Stack Help
	Improve		Extras	Learn

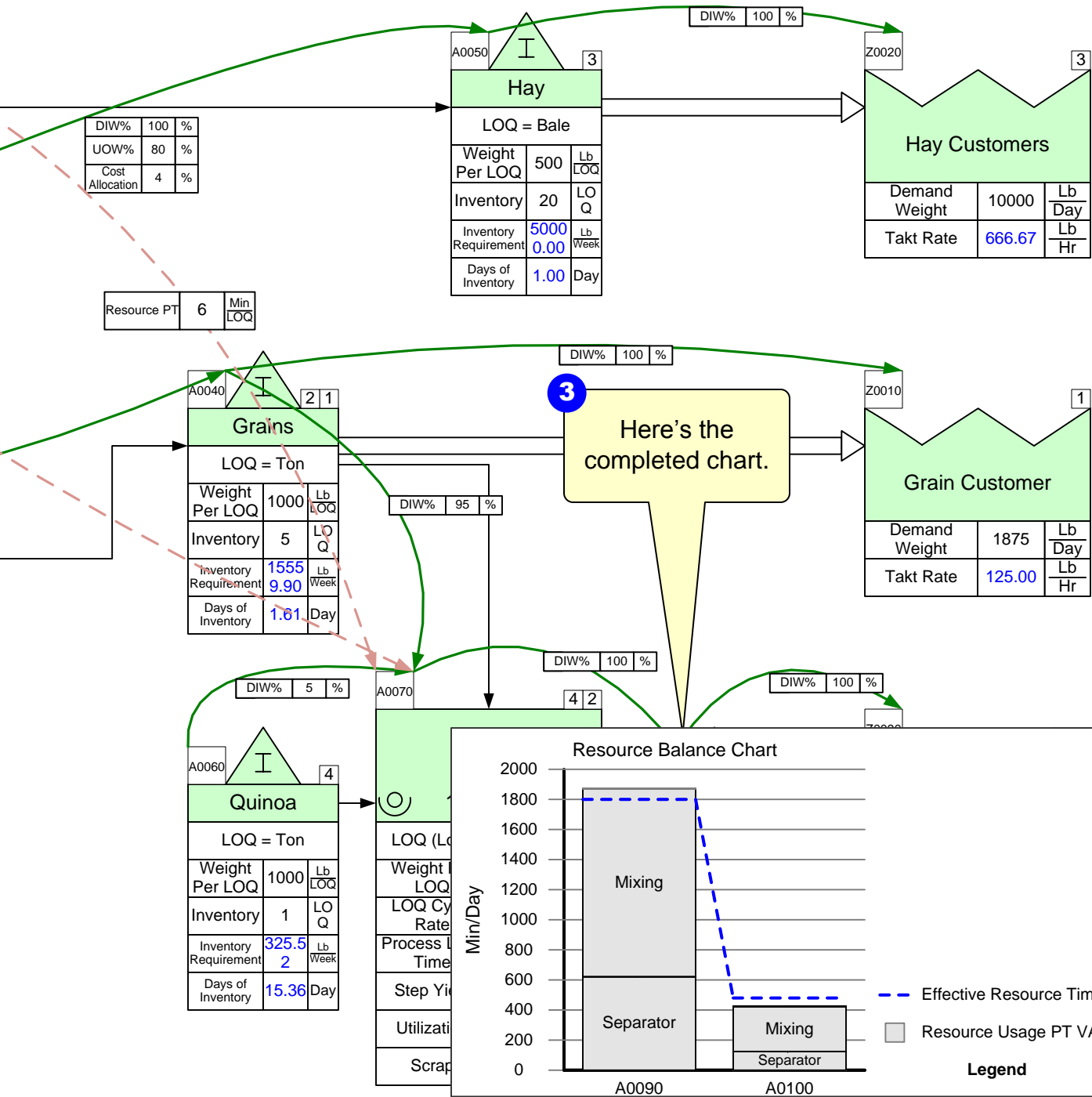

3 Here's the completed chart.

-
-
- TRASH LIST**
-
-
-
-
-
-
-
-
-
-
-
-

Step 21: Making VA/NVA Timeline Visible

Variable Visibility

Center/Addon Name	Variable Name(s)	Visibility
Inventory Cost/Value	Inventory Unit Cost	<input type="checkbox"/>
	Non Value Added	<input checked="" type="checkbox"/>
	Start Time	<input type="checkbox"/>
	Duration	<input type="checkbox"/>
	End Time	<input type="checkbox"/>
Activity Center	Associates	<input checked="" type="checkbox"/>
	Descriptor	<input checked="" type="checkbox"/>
	Weight Per LOQ	<input checked="" type="checkbox"/>
	LOQ Cycle Rate	<input checked="" type="checkbox"/>
	Process Lead Time	<input checked="" type="checkbox"/>
	Step Yield	<input checked="" type="checkbox"/>
	Utilization	<input checked="" type="checkbox"/>
	Value Added	<input checked="" type="checkbox"/>
	Activity Output Takt Rate	<input type="checkbox"/>

2 Check the visibility box for Non Value Added

3 Check the visibility box for Value Added

4 Once you click OK, the timeline will appear under the appropriate centers

Inventory Requirement	9724	Lb	Week
Days of Inventory	1.29	Day	

Process Lead Time	55	Min
Step Yield	80	%
Utilization	103.73	%
Setups	1	StUp Day
Time Per Setup	40	Min StUp

19.28 Hr

55.00 Min

Day	Week
15	5
Hr	Day

